

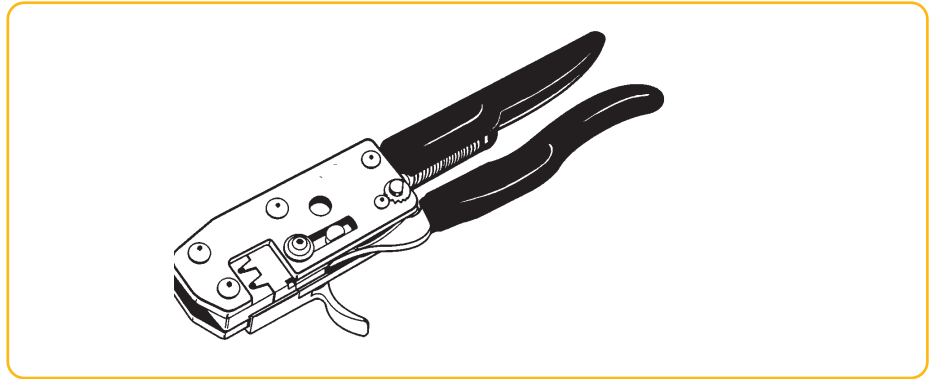

DUBOX™ CONTACT

HAND TOOL HT 234

- Simple and reliable
- Low operation force
- Lightweight hand tool
- Contains two toolings (AWG 22-24, AWG 26-30)



ORDERING DATA

For use with Dubox™ contacts, loose piece

Part number	76357-x01	AWG 22-24/26-30	HT 234
-------------	-----------	-----------------	---------------

HAND TOOL HT 250 / HT 251

- Simple and reliable
 - Low operation force
 - Lightweight hand tool
 - Reel fed
 - Seperate toolings:
 - HT 250 for AWG 22-24
 - HT 251 for AWG 26-30
- For use with Dubox™ contacts, on reel

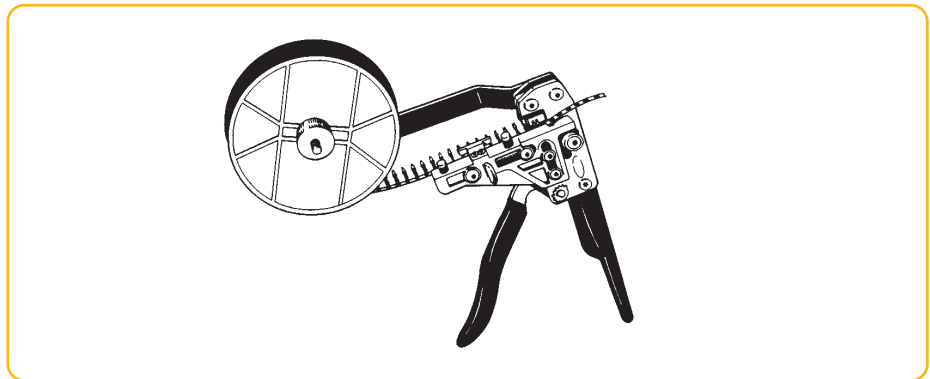

ORDERING DATA

For use with Dubox™ contacts, on reel

Part number	76347-x03	AWG 22-24	HT 250
Part number	76347-x03	AWG 26-30	HT 251

Application rate/hour	500 (depending on operator dexterity)
Weight	1 kg
Dimensions (h x w)	305 x 230 mm

DUBOX™ CONTACT

STRIPPER-CRIMPER DX 271

- ▶ Simple operation
- ▶ High speed crimping
- ▶ Strips and crimps the wire in one operation
- ▶ Lightweight construction
- ▶ Pneumatically operated
- ▶ Adjustable tooling
- ▶ High quality results

ORDERING DATA

DX 271 Press & Tooling	AWG 24-26	191230-01
Tooling Kit	AWG 24-26	193830-01
Tooling Kit, small insulation	AWG 20-22	193830-02
Tooling Kit, small insulation	AWG 28-32	193830-03
DX 271 Press only		191000-00

Application rate/hour	1800 (depending on operator dexterity)
Weight	32 kg
Dimensions (h x w x d)	980 x 600 x 400 mm
Working height above table	85 mm
Air consumption / min.	61 NI
Air pressure	5-6 Bar

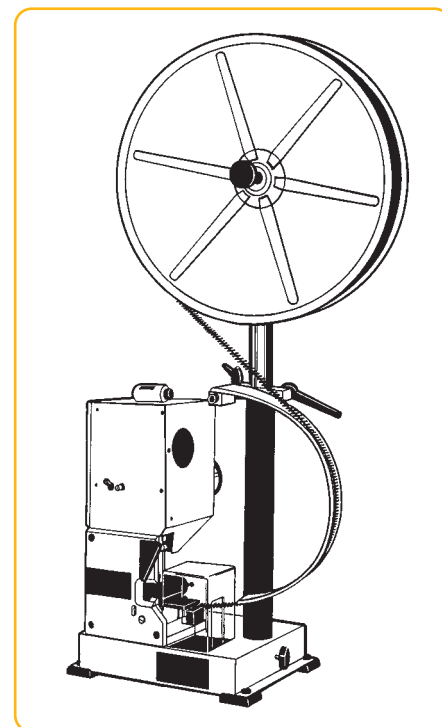

BergStik® HEADER

CUTTING TOOL HT 320

- ▶ Simple and reliable
- ▶ Low operation force
- ▶ Lightweight hand tool

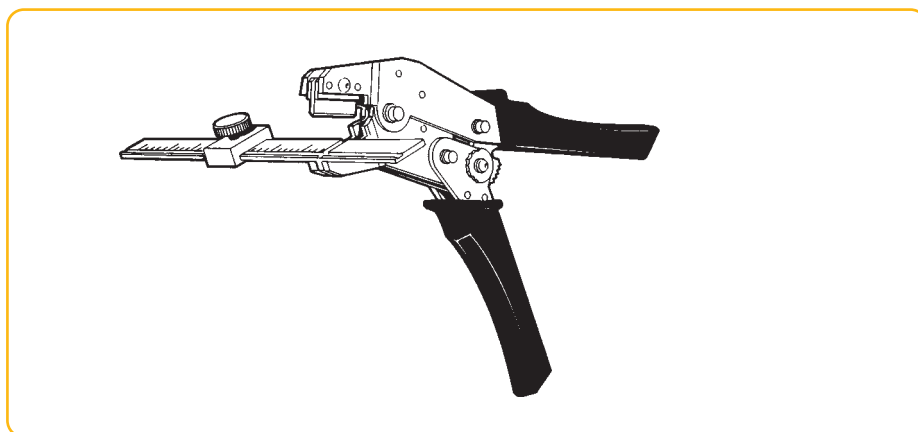

ORDERING DATA

For use with BergStik® Headers

Part number 77311, 77313, 77315, 77317

HT 320



MINITEK™ CONTACT

STRIPPER-CRIMPER MK 271

- Simple and reliable
- High speed crimping
- Strips and crimps the wire in one operation
- Lightweight construction
- Pneumatically operated
- Adjustable tooling
- High quality results

ORDERING DATA

MK 271 Press & Tooling	AWG 26-30	193315-01
Tooling Kit	AWG 26-30	193317-01
DX 271 Press only		193316-01

Application rate/hour	1500 (depending on operator dexterity)
Weight	32 kg
Dimensions (h x w x d)	980 x 600 x 400 mm
Working height above table	85 mm
Air consumption / min.	61 NI
Air pressure	5-6 Bar

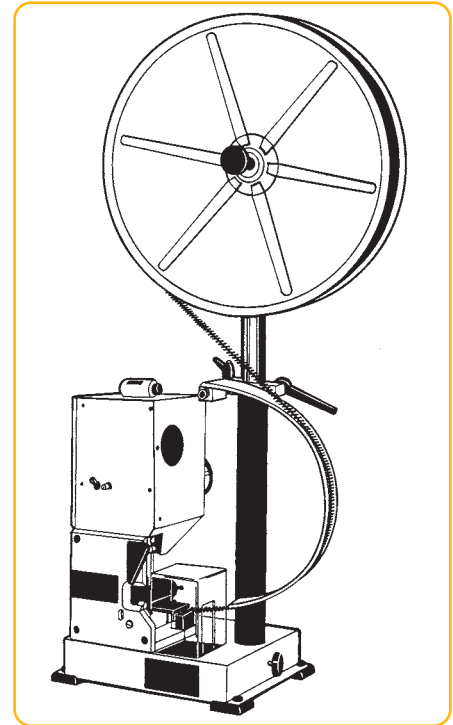

HAND TOOL HT 151 / HT 152

- Lightweight hand tool
- Rugged
- Ratched-action handle assures complete crimp cycle

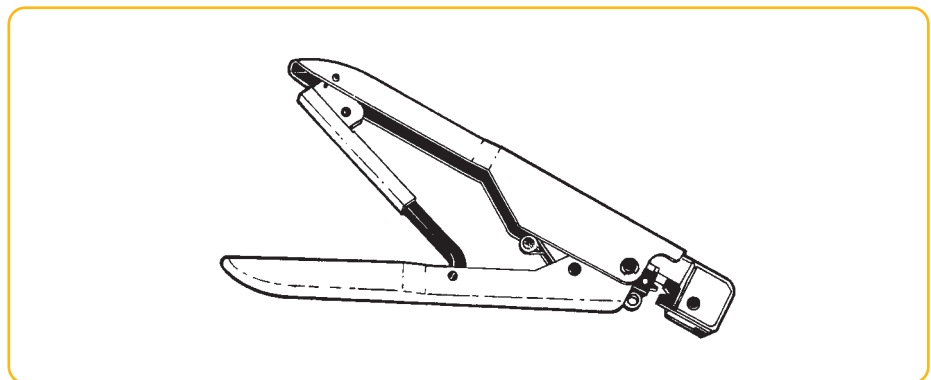

ORDERING DATA

For use with Dubox™ contacts, on reel

	AWG 26-30	HT 151
	AWG 32-36	HT 152

DUBOX™ CONTACT

STRIPPER-CRIMPER DX 271

- ▲ Simple operation
- ▲ Reliable
- ▲ Pneumatically operated
- ▲ Low maintenance cost
- ▲ High quality results

ORDERING DATA

MK 411 Press & Tooling	AWG 26-30	194294-01
MK 411 Press & Tooling	AWG 32-36	194294-02

Application rate/hour	1800 (depending on operator dexterity)
Weight	25 kg
Dimensions (h x w x d)	710 x 560 x 400 mm
Working height above table	110 mm
Air consumption / min.	28 NI
Air pressure	5-6 Bar
Electrical requirements	220-240V, 50Hz, 0,5A

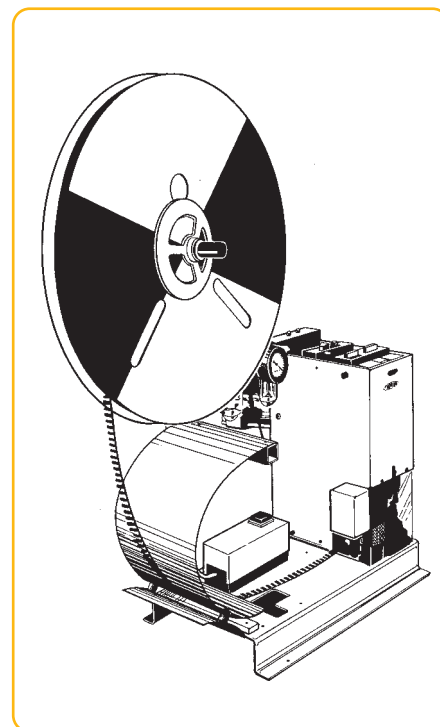



PV™ CONTACT

APPLICATION TOOLING

■ PV™-250A Semi-automatic Crimping

- Easy to use
- Pneumatically operated
- Low cost
- Estimated 1000 crimps per hour

■ Machine Part Number

- 107416-101 (18-20AWG)
- 107416-102 (22-26AWG)
- 107416-103 (28-32AWG)

■ OL-740 Semi-automatic Two Ton Bench Press

- Uses quick-changing, adjustable crimping applicators for different terminals and wire sizes
- Most rugged construction
- Easy to use
- Electrically operated
- Estimated 2400 crimps per hour

■ Machine Part Number

- 133911-102
(does not include applicator)

■ Applicator Tooling Part Numbers

- 133867-104 (18-20AWG)
- 133867-105 (22-26AWG)
- 133867-106 (28-32AWG)

■ Ratcheting Hand Crimping Tool

■ Part Number

- HT-0073 (for 18-20 AWG Wire)
- HT-0096 (for 22-32 AWG Wire)
- HT-0112 (for 32-36 AWG Wire)

■ PV™ Contact Removable Tool

■ Part Number

- HT-0080

BASE PART NUMBER	PAGE	BASE PART NUMBER	PAGE
48045	41	72454	47
48046	41	75543	41
48047	41	75867	45
48048	41	75869	45
48049	41	75915	25
48050	41	76341	27
48051	41	76342	27
48052	41	76347	35
48231	41	76357	35
55508	61	76382	33
55510	61	76383	33
57102	55	76384	33
57202	55	76385	33
59112	59	77138	69
59132	59	77139	69
59202	59	77311	11
63429	23	77313	11
63453	61	77315	17
65039	43	77317	17
65043	43	78207	39
65239	37	78208	39
65240	37	78211	43
65846	43	86730	63
67996	13, 15	87606	25
67997	13, 15	89361	71
68000	13, 15	89882	31
68001	13, 15	89883	31
68002	13, 15	89891	25
68015	19	89898	29
68016	19	89947	71
68020	19	90311	69
68021	19	91596	61
68602	13, 15	91601	29
68786	23	91614	29
69145	23	91615	29
69167	39	91618	29
69168	39	95278	11
69307	69	95293	11
69830	53	98401	11
71600	51	98414	65
71607	31	98423	57
71609	31	98424	65
71918	49	98464	67
71920	25	10056844	47
71922	49	10056845	47
71991	27		

For more information about e-catalog or FCI
sales offices, headquarters, agents and local distributors,
visit www.fciconnect.com



Americas - Phone: 1 (800) 237 2374 ■ Europe - Phone: 33 1 39 49 21 83 ■ Asia/Pacific- Phone: 65 6549 6666