

	<b>PRODUCT SPECIFICATION</b> <b>MINITEK CONNECTOR</b>	<b>F C I JAPAN</b>
---	--	--------------------

1. SCOPE

This specification is intended to cover the performance and evaluation conditions for MINITEK Connector when tested on the applicable maximum size of wire.

2. MATERIAL and FINISH

2.1 Terminal

Material : Phosphor bronze  
 Finish : 0.2 μm min. or 0.76 μm min. gold plating in the contact area,  
 over 1.27 μm min. nickel underplating.

2.2 Housing

Material : Nylon 66, black  
 Flammability : UL 94V-0

2.3 Header

2.3.1 Pin

Material : Brass  
 Finish : 0.2 μm min. or 0.76 μm min. gold plating in the contact area, and  
 3.8 μm min. tin/lead (lead 10%) plating over 1.27 μm min. nickel  
 underplating

2.3.2 Body

Material : Glass-filled Nylon, black  
 Flammability : UL94V-0

3. Performance Requirements

3.1 Rating Voltage : 200V, AC / DC

3.2 Rating Current : 2A, AC / DC

3.3 Operating Temperature Range : -40 °C to 105 °C  
 ( Including temperature rise caused by application of current. )

				<b>PREP'D</b>	<b>NO :</b>  110-036	<b>REV.</b>  G
G	New FCI Logo-V06-1029	10/1006	CL	<b>BY:</b> <i>Y.Awano</i>		
F	REVISED (ECN455)	6/23/87	N.Y.	<b>ISS'D</b>		
E	REVISED	8/28/86	N.Y.	<b>BY:</b> <i>Y.Awano</i>		
D	REVISED	11/27/85	N.Y.	<b>APPR'D</b>		
<b>REV</b>	<b>CONTENTS</b>	<b>DATE</b>	<b>BY</b>	<b>BY:</b> <i>I.Ito</i>		

### 3.4. Performance

Unless otherwise specified, when tested under the ambient conditions in accordance with JIS-C-0010 as described below and evaluated with the sequence listed in Table. 2. the connector shall meet the requirements in paragraph 3.5.

Temperature : 5 °C ~ 35 °C  
Relative Humidity : 45 % ~ 85 %  
Atmospheric Pressure : 860 hPa ~ 1060 hPa

### 3.5. Requirements

#### 3.5.1 Electrical Characteristics

##### 3.5.1.1 Contact resistance

The contact resistance shall not exceed 15 mΩ before test or 20 mΩ after test when measured under the following conditions

- (a) Method of Connection : See Figure 1
- (b) Test Current : 10 mA DC
- (c) Open Circuit Voltage : 20 mV DC

##### 3.5.1.2 Insulation Resistance

The insulation resistance of the unmated connector shall be not less than 1000 MΩ when measured in accordance with MIL-STD-202, Method 302. The following details shall apply :

- (a) Test voltage : 500V DC for 1 minute
- (b) Special preparation : The connector shall not be mounted on PCB.
- (c) Points of measurement : Between adjacent terminals

##### 3.5.1.3 Dielectric Withstanding Voltage

There shall be no evidence of arc-over or insulation breakdown when the unmated connector is tested in accordance with MIL-STD-202, Method 301. The following details shall apply :

- (a) Test voltage : 650 V AC for 1 minute
- (b) Special preparation : The connector shall not be mounted on PCB.
- (c) Points of measurement : Between adjacent terminals.

NO.	REV.
110-036	G

3.5.1.4 Temperature rise

The temperature rise shall not exceed 30 degree C when measured using thermocouple under the following conditions.

- (a) Current applied : 2A DC
- (b) Special preparation : The connector shall be connected in series
- (c) Points of measurement : At a terminal located at or near the middle of the connector.

3.5.2 Environmental Characteristics

3.5.2.1. High Temperature

There shall be no evidence of cracking, swelling or other damage which would be detrimental to the function of the connector. The contact resistance shall not exceed 20 mΩ after the mated connector is exposed to a high temperature environment in accordance with MIL-STD-202, Method 108 A.

The following details shall apply :

- (a) Ambient Temperature : 105 ± 2 °C
- (b) Duration : 44 hours

3.5.2.2. Humidity

There shall be no evidence of cracking, swelling or other damage which would be detrimental to the function of the connector after the mated connector is exposed to a high humidity ambience in accordance with MIL-STD-202, Method 103 B.

The contact resistance shall not exceed 20 mΩ, and insulation resistance shall be not less than 100 MΩ.

The dielectric withstanding voltage test shall be performed after the humidity test, and the connector shall meet the requirements described in paragraph 3.5.1.3.

The following details shall apply :

- (a) Ambient Temperature : 40 ± 2 °C
- (b) Relative Humidity : 90 to 95 %
- (c) Duration : 96 hours

NO.	REV.
110-036	G

3.5.2.3. Salt spray

There shall be no evidence of cracking, swelling or oxidation which would be detrimental to the function of the connector, and the contact resistance shall not Exceed 20 mΩ after the mated connector is exposed to a salt fog ambience in accordance with MIL-STD-202, Method 101.

The following details shall apply :

- (a) Salt Solution : 5 % by weight
- (b) Ambient Temperature : 35°C
- (c) Duration : 48 hours
- (d) Special Treatment : The measurement shall be conducted after the mated connector is mildly rinsed in running water to remove deposition of salt, followed by natural drying by placing it for 24 hours at room temperature.

3.5.2.4. Thermal Shock

There shall be no evidence of cracking, swelling or other damage which would be detrimental to the function of the connector after the mated connector is exposed to alternate cycles of extreme high and low temperature in accordance with MIL-STD-202, Method 107D. The contact resistance shall not exceed 20 mΩ.

The following details shall apply:

- (a) Temperature range : -55 +0/-3 °C for 30 minutes followed by  
85 +3/-0 °C for 30 minutes.
- (b) Number of cycles : 5 cycles

3.5.2.5. Hydrogen Sulfide (H<sub>2</sub>S) Exposure

There shall be no evidence of cracking, swelling or oxidation which would be detrimental to the function of the connector, and the contact resistance shall not exceed 20 mΩ after the mated connector is exposed to a moist H<sub>2</sub>S environment.

The following details shall apply:

- (a) Ambient Temperature : 40 °C
- (b) Relative Humidity : 75 to 80 %
- (c) H<sub>2</sub>S Density : 10 ± 5 ppm
- (d) Duration : 96 hours

3.5.3 Mechanical Characteristics

3.5.3.1. Vibration

There shall be no evidence of physical or mechanical damage, or disassociation of parts, and no evidence of discontinuity greater than 1 microsecond when the mated connector is subjected to mechanical vibration. The contact resistance shall not exceed 20 mΩ after the test. The test shall be in accordance with MIL-STD-202, Method 201. The following details shall apply :

NO.	REV.
110-036	G

- (a) Frequency : 10-55-10 Hz / MIN. sweep vibration
- (b) Amplitude : 1.5 mm MAX.
- (c) Test Current : 0.1 A
- (d) Duration : 2 hours in each of three perpendicular axes. ( 6 hours total )
- (e) Mounting : See Figure 2

3.5.3.2. Contact Retention Force

Each contact retention force shall be more than 7.85N(0.8kgf) when crimped terminal is pulled up along axial direction at the speed of 25 mm / min.

3.5.3.3. Post Retention Force

Each post retention force shall be more than 9.8 N (1.0kgf) when the post is pushed along axial direction at the speed of 25 mm / min.

3.5.3.4. Crimp strength

Crimp strength on each specified wire size shall meet the requirements in Table 1. when the crimped wire is pulled along axial direction at the speed of 25 mm/min.

Table 1.

AWG	mm <sup>2</sup>	Crimp strength	
26	0.13	19.6 N m in.	2.0 Kg m in.
28	0.08	11.8	1.2
30	0.05	6.9	0.7
32	0.03	2.0	0.2
34	0.02	2.0	0.2
36	0.01	1.5	0.15

3.5.3.5. Mating / Unmating Force

When the connector is subjected to 20 cycles of mating / unmating operation, insertion and withdrawal forces shall conform to the following requirements :

- (a) Insertion Force : 5.4 N (550 g) x pos. MAX.
- (b) Withdrawal force : 0.49 N (50 g) x pos. MIN.

3.5.3.6. Durability

Contact resistance after 100 cycles of mating / unmating operation shall not exceed 20 mΩ

NO.	REV.
110-036	G

### 3.5.3.7. Solderability

No less than 90% of the dipped surface of the solder leg shall be wet when each solder leg is dipped in a solder bath. The test shall be in accordance with MIL-STD-202, Method 208C, and the following details shall apply.

- (a) Flux : alpha 100, GX-5 or GX-7.
- (b) Solder : 60/40 Tin-lead.
- (c) Flux immersion time : 5 to 10 seconds.
- (d) Solder temperature : 230 +/- 5 °C
- (e) Dipping time : 3 +/- 0.5 seconds

### 3.5.3.8. Solder-Heat Resistance

There shall be no evidence of physical damage detrimental to the function of the connector when each solder leg of the connector mounted onto a pc board is dipped in a bath.

The following details shall apply :

- (a) Solder Temperature : 260 +/- 5 °C
- (b) Dipping time : 5 +/- 0.5 seconds.
- (c) Immersion depth : The end of the solder leg coming thru the pcboard.

NO.	REV.
110-036	G

Table 2 Test Sequence

	Test Description	Test Group															Test Method
		1	2	3	4	5	6	7	8	9	10	11	12	13	14	15	
1	Contact Resistance			① ③	① ③	① ③	① ③	① ③	① ③					① ③			3.5.1.1
2	Insulation Resistance	①			④ ⑤												3.5.1.2
3	Dielectric Withstanding Voltage	②															3.5.1.3
4	Temperature Rise		①														3.5.1.4
5	High Temperature			②													3.5.2.1
6	Humidity				②												3.5.2.2
7	Salt Spray					②											3.5.2.3
8	Thermal Shock						②										3.5.2.4
9	H2S Exposure							②									3.5.2.5
10	Vibration								②								3.5.3.1
11	Contact Retention Force									①							3.5.3.2
12	Post Retention Force										①						3.5.3.3
13	Crimp strength											①					3.5.3.4
14	Mating/Unmating Force												①				3.5.3.5
15	Durability													②			3.5.3.6
16	Solderability														①		3.5.3.7
17	Solder Heat Resistance															①	3.5.3.8

Note : Numbers indicate sequence in which tests are performed.

NO.	REV.
110-036	G

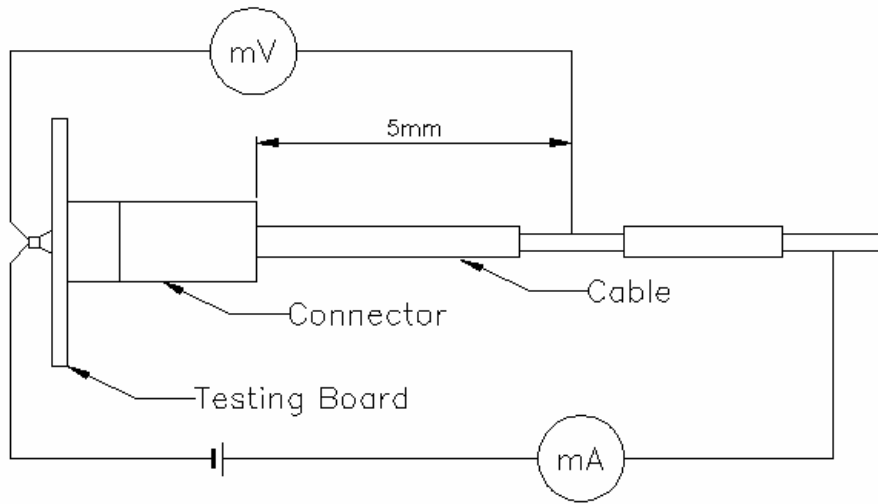

FIG.1

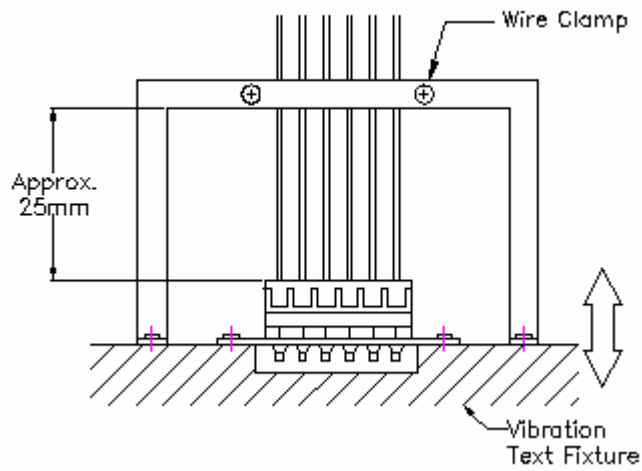

FIG.2

NO.	REV.
110-036	G