

Straddle-mount Micropax™ Connectors

Application Note

Overview

This note covers the recommended application of straddle mount plugs and receptacles to aid both design engineers and manufacturing engineers in the proper use of Micropax™ connectors. It is intended to be used as the starting place for process development; but, due to the unique differences in our customer's needs (i.e., board thickness, component density, single or double sided PCB, reflow process, etc.), it is impossible to define a process that will work everytime in all situations.

In order to apply a high density connector successfully, the user needs to follow the majority of FCI's recommendations but may find it necessary to vary some process settings to accommodate your unique circumstances.

Product drawings

- Drawings are available for each Micropax connector part number by calling either technical service or FCI Fax™ at 1-800-237-2374.

- In the event of a conflict between this note and the drawing, the drawing will take precedence.

General connector application features:

- Compliant straddle mount tails to compensate for variations in board thickness tolerances. See Figure A.
- Staggered straddle mount tails to allow easy inspection and repair. See Figure A.
- Board alignment is accomplished by features which are integral to the cast metal shell that assures proper alignment of the straddle mount tails to the PCB solder pads when the PCB is properly routed. See Figure A.
- Connector strain relief is provided by direct connector to PC board attachment by screws. See Figure A.
- Connectors are shipped with a processing cap (see Figure A) to:
 - Prevent receptacle nose piece bowing during reflow by removing

Figure A

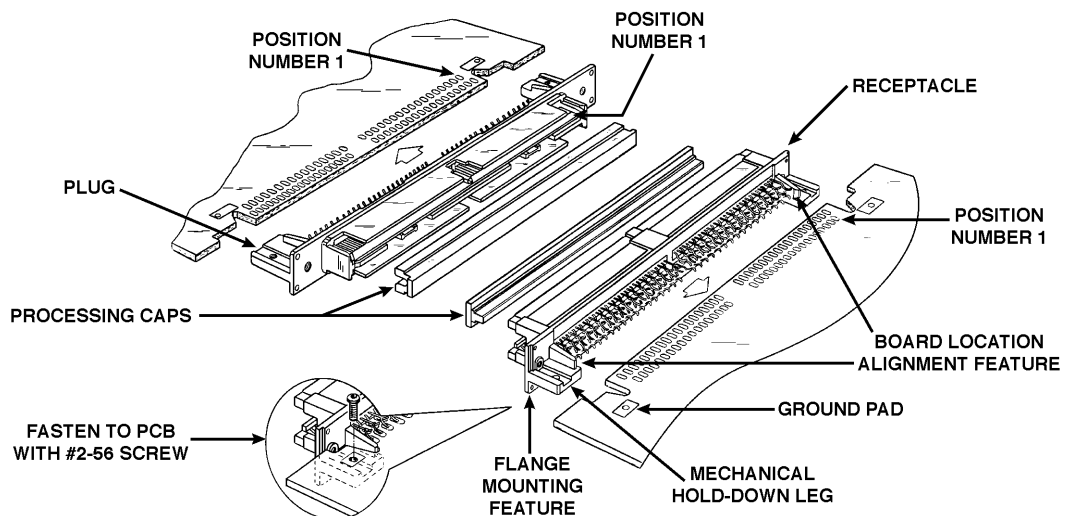

terminal preload from the nose piece

- Prevents movement of plug tails during reflow.
- Protect contacts from damage and dust during handling.
- Reduces flux contamination
- Pre-deposited 60/40 solder on straddlemount tails. See Figure B.
 - Eliminates the need to solder paste the PCB pads.
 - Eliminates the plowing of solder paste during connector application
 - Eliminates solder bridging
 - Provides two pounds of retention per solder joint.
- Connectors are supplied in clear anti-static tubes, 24 inches long.

Figure B

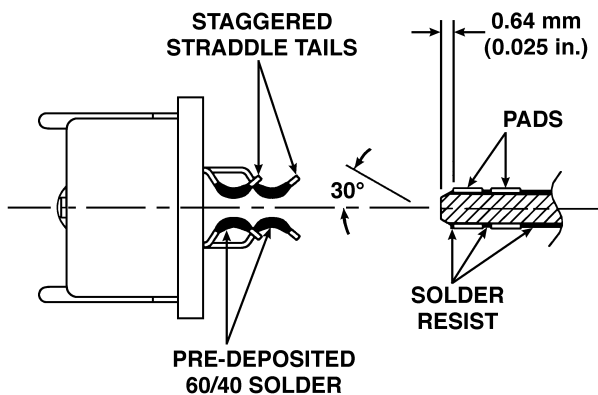

PC Board Design

- FCI's catalog product is designed for standard 0.062" + 10% thick PC boards. Contact your FCI sales representative for other board thicknesses.
- Boards should be built with a 30° x 0.025" bevel both top and bottom to reduce connector assembly to board forces and prevent solder tail buckling. See Figure B.
- A solder resist should be applied around all PCB connector pads to prevent solder bridging between contact tails. See Figure B.

Figure C

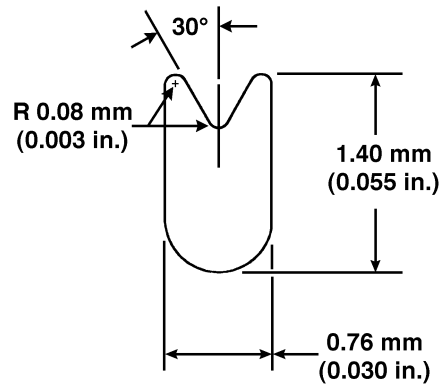

- Pad design should utilize the tulip shaped pad as shown in Figure C. This shape helps align the straddle tail on the pad during connector assembly to board.
- Boards need to be routed per Figure D to assure proper board to connector alignment.
- For a #2-56 screw, use a mounting hole size of 0.110 + .003" diameter. See Figure D.

Figure D

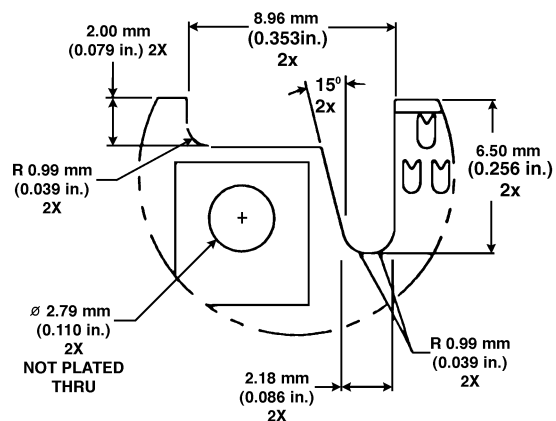

- Pads and mounting holes should be located per Figure E.

Figure E

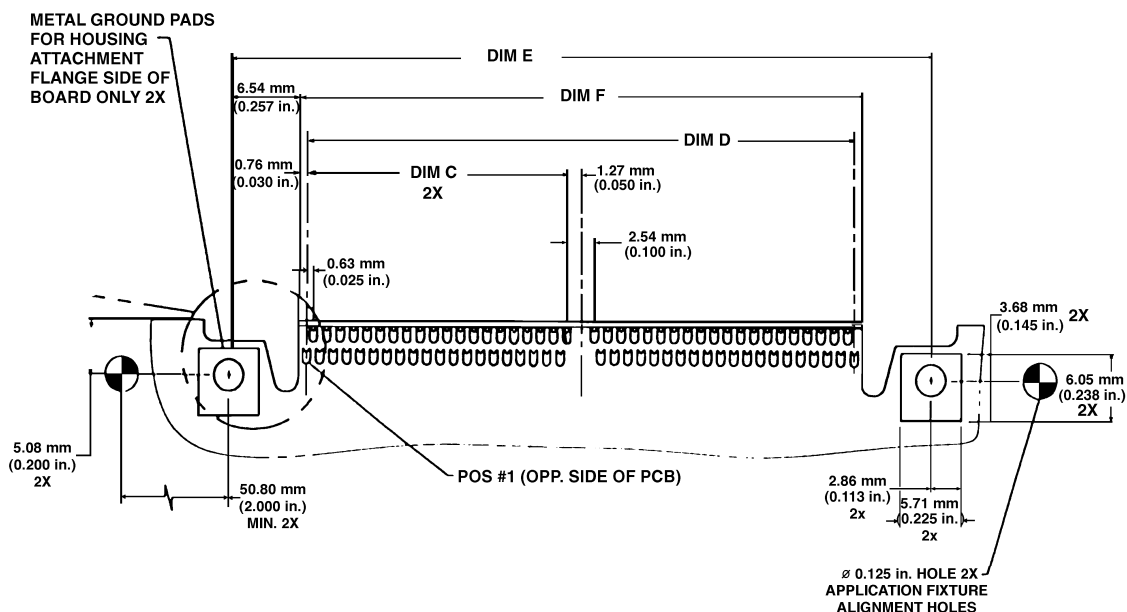

Number of Contacts	Dim. C mm inch	Dim. D mm inch	Dim. E mm inch	Dim. F mm inch	Board Thickness mm inch	Solder Bump	Contact Plating
120	<u>18.42</u> 0.725	<u>39.37</u> 1.550	<u>53.98</u> 2.125	<u>40.89</u> 1.610	<u>1.58</u> 0.062	YES	GXT™
160	<u>24.76</u> 0.975	<u>52.07</u> 2.050	<u>66.68</u> 2.625	<u>53.59</u> 2.110	<u>1.58</u> 0.062	YES	GXT™
200	<u>31.12</u> 1.225	<u>64.77</u> 2.550	<u>79.38</u> 3.125	<u>66.29</u> 2.610	<u>1.58</u> 0.062	YES	GXT™

Recommended solder reflow process:

- **Step 1** - Solder pad fluxing
 - Apply a paste flux to pads and chamfered board edge. The flux serves a dual purpose of fluxing the pads and lubricating the board for easy connector placement.
- **Step 2** - Connector placement
 - Utilize a custom made assembly fixture to slide connector accurately into position to eliminate springing the straddle tails open and to keep from stubbing the tails. Fixtures can either be custom built by FCI or FCI can help you design and build your own.
 - Carefully remove connectors from tubes. Do not spill out on the table or tail damage could occur. Connectors should be kept

in anti-static shipping tubes until being placed to protect straddle tails from damage.

- **Step 3** - Connector holddown and strain relief
 - Utilize a #2-56 x 3-16 long screw for a 0.062 thick board.
- **Step 4** - Solder reflow
 - Dust caps need to be in place until after the connector has been soldered to the PC board.
 - Elevate the board off of the reflow belt to assure both sides of the connector tails get uniform heat.
 - Forced hot air convection is the recommended heat source but IR vapor phase, hot bar, and localized hot air will also work.

- Recommended soldering temperature profile:

	Temperature °C	Time Minutes
Ramp-up	25° to 150°	1 to 2.5
Soak	150°	2 max.
Reflow	183°	1 to 2
Ramp down	183° to 50°	1 to 3

- All recommended temperatures are on the board near the solder tails.
- The maximum total cumulative time to ramp-up, soak, and reflow the board should not exceed 5.5 minutes.
- Maximum temperature on the board should not exceed 230°C for more than 10 seconds.

- **Step 5** - Wash board to remove solder flux
 - Remove process cap if practical to facilitate cleaning.
 - Connector contact area must be free of flux residue to assure reliable electrical interface.

- Be careful that connector contact area is not contaminated with flux during any rework or board touch-up.

- **Step 6** - Inspect solder joint
 - A minimum of 50% of the solder tail width should be on the solder pad per ANSI/IPC standard -D-300G.
- **Connector mating**
 - Connector must be fully mated to assure a reliable electrical interconnection. The maximum allowable disengagement from the fully seated position should not exceed 0.015 inches.
 - PC boards should be locked into position after mating to prevent connector rocking or unmating due to equipment vibration or board twisting.
 - For information on maximum allowable connector to connector misalignment see TA drawing number TA-932. It is available by calling FCI Fax™ at 800-237-2374 or 717-938-7212.

U.S.A. Tel.: (800) 237-2374; 717-938-7200

Canada Tel.: 905-826-9810

Europe Tel.: 31-73-6206-911

Asia/Pacific Tel.: 65-549-6666

