

TABLE OF CONTENTS

UNIRAP™

- Cable Tie Features and Specs . . . **G-2 - G-4**
- Military Spec Cable Ties **G-5**
- Standard Cable Ties **G-6 - G-7**
- Releaseable Cable Ties **G-8**
- Identification Cable Ties **G-9**
- Mounting Hole Cable Ties **G-9**
- Halar® Cable Ties **G-10**
- Tefzel® Cable Ties **G-10**

Type TFV-B

- Hook and Loop Straps **G-11**

Mounting Bases

- (4-Way) **G-12**
- (2-Way) **G-12**

Cable Hangers

- **G-13**

Stainless Steel Accessories

- Stainless Steel Ties **G-14**

Cable Tie Tools

- **G-15**

G-1

Throughout the catalog you will notice blue highlighted items. These are the most frequently ordered BURNDY® Products.

UNIRAP™

NYLON CABLE TIES

UNIRAP™ cable ties are fabricated of one-piece Nylon with no metal parts. The straps are tough, resilient, lightweight and abrasion resistant. They offer high tensile strength and are chemically resistive to solvents, alkalis, oils, grease and diluted acids. Self-locking, they secure without twisting or leaving sharp projections.

Compact heads and pre-bent tips facilitate cable bundling in a minimum of time and space.

UNIRAP™ cable ties are designed for both field and production line use and may be installed easily by hand.

FCI BURNDY® cable ties consist of three components: strap, head, and tail. These components are specifically designed to function together to make FCI BURNDY® UNIRAP™ cable ties superior in quality and performance.

G-2

Component

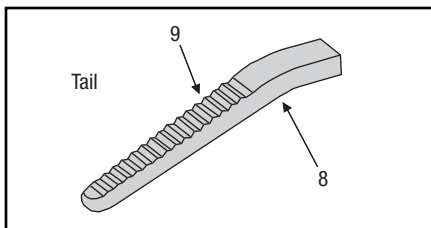
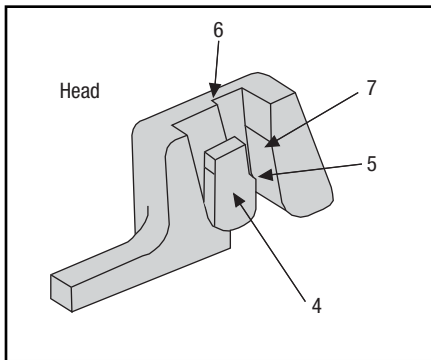
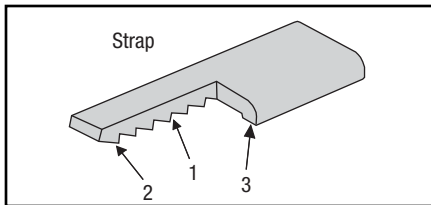

Precision Engineering

1. Includes load bearing **serrations**.
2. Features **flats** between the serrations.
3. Features the **double outer rail system**.
4. The **pawl** is integrally formed with the head.
5. The **pawl** is stepped in order to wedge against the serrations in the strap to form the lock.
6. The **shoulders**, or the sides of the head, guide the strap and prevent it from disengaging from the pawl during loaded conditions.
7. The **back** supports the strap during the wedging of the lock formation.

Enhanced Performance

1. Serrations provide complete adjustability within the fastening range.
2. Flats reduce stress concentrations and help make the tie stronger.
3. Smooth rails promote low drag, as well as minimize chafing.
4. The locking unit will not disengage. It also promotes low insertion with high pull out force for very easy installation.
5. The tie's ultimate strength achieves optimum levels.
6. Promotes cable tie strength, endurance, and longevity.
7. Ensures optimum locking capability.
8. Easy pick-up for installers, which leads to fast assembly.
9. Allows for easy, no-slip grip.

Throughout the catalog you will notice blue highlighted items. These are the most frequently ordered BURNDY® Products.

Available Materials

Nylon 6/6 – General Purpose

General purpose nylon 6/6 features light weight, high strength and a wide temperature range. It is halogen free so it does not release dangerous gases, such as chlorine, bromine, fluorine and iodine when burned. Nylon 6/6 is hygroscopic, and therefore, absorbs or releases moisture depending on its environment. Thus, the moisture level of the material will affect tensile strength, stiffness and elongation of the product.

Nylon 6/6 – Heat Stabilized

With similar properties and benefits as nylon 6/6, products manufactured with heat stabilized nylon 6/6 material have a chemical stabilizer added for higher continuous temperature applications.

Nylon 6/6 – UV Stabilized

Chemical inhibitors are used to give nylon 6/6 material added properties to fight against premature aging of products due to the effects of ultraviolet rays.

Nylon 6/6 – UV Stabilized (2% Carbon for Military Specification)

The physical properties of this material include carbon, which acts as a UV stabiliz-

er, prolonging the life of the product under ultraviolet conditions. It also allows cable ties to meet the particular military specification for cable ties.

Nylon 6/6 – V0 Flame Retardant

This material meets UL 94V-0 flammability requirements. Flame retardant additives generally reduce tensile strength when compared to general-purpose nylon 6/6, but this resin has been formulated to minimize such effects.

Nylon 6/6 – High Impact

Impact modifiers are added to increase flexibility. High impact nylon 6/6 has stable tensile strength due to its reduced influence from moisture. It is excellent for high vibration applications, as within the aircraft and automobile industries and performs better than nylon 6/6 against ultraviolet rays. Good for outdoor use.

Polypropylene

Polypropylene is used in environments where chemical effects on nylon are a concern. It is not affected by inorganic acids (hydrochloric), polyhydric alcohols (ethyleneglycol), neutral salts (sodium chloride) and basic

salts (sodium bicarbonate). Polypropylene also resists a number of other chemicals with good results, although it has lower tensile strength than nylon 6/6 (about half). Polypropylene has good UV resistance.

Tefzel®

Although about two-thirds the strength of nylon 6/6, Tefzel is resistant to a wide range of chemicals, such as concentrated hydrofluoric and sulfuric acids. It is also a low water absorbing material, therefore, is not adversely affected by water. Tefzel is radiation resistant up to 100 megarads and meets the fire and smoke requirements of IEEE 383. Tefzel also withstands high temperatures and ultraviolet light exposure. Products made from Tefzel material also have non-outgassing properties for zero gravity applications.

Halar®

Halar is similar to Tefzel in performance and benefits. Halar is recognized for its low smoke density attribute when burned. This makes products made out of Halar more desirable for use in areas where smoke generation is a concern, as when bundling wire and cable in air handling spaces.

G-3

Material Specifications

Material	Continuous* Operating Temperature		Tensile Strength at 73° F Dry as Molded ASTM D-638 (PSI)	UL Flame Rating	Oxygen Index %	Gamma Radiation Resistance	UV Resistance	Military, Federal, ASTM, and FDA Specifications
	Max.	Min.						
Nylon 6/6 — General Purpose (CT)	185° F 85° C	-40° F -40° C	12,000	94V-2	28	1 × 10 ⁵ Rads	Poor	ASTM D-4066PA0111 FDA CFR177.1500
Nylon 6/6 — Heat Stabilized (CTHS)	220° F 105° C	-40° F -40° C	12,000	94V-2	26	1 × 10 ⁵ Rads	Poor	ASTM D-4066PA0121
Nylon 6/6 — UV Stabilized (O)	185° C 85° C	-40° F -40° C	12,000	94V-2	26	1 × 10 ⁵ Rads	Good	ASTM D4066PA0191
Nylon 6/6 — 2% Carbon UV Stabilized (OO)	220° F 105° C	-40° F -40° C	12,000	94V-2	26	1 × 10 ⁵ Rads	Good	ASTM D-4066PA0181 MS3367/8
Nylon 6/6 — Flame Retardant (CTV)	185° F 85° C	-40° F -40° C	10,800	94V-0	34	1 × 10 ⁵ Rads	Poor	ASTM D-4066PA0110
Nylon 6/6 — High Impact	185° F 85° C	-40° F -40° C	8,800	94-HB	19	1 × 10 ⁵ Rads	Good	ASTM D-4066PA0150
Polypropylene — Chemical Resistant (CTPP)	185° F 85° C	-40° F -40° C	3,400	94-HB	N/A	1 × 10 ⁵ Rads	Good	ASTM D-4101PP0320 FDA CFR177.1520
Nylon 12 — UV Stabilized	176° F 80° C	-40° F -40° C	5,800	94-HB	N/A	9 × 10 ⁶ Rads	Good	ASTM D-4066PA411
Tefzel® (CTZ)	302° F 150° C	-50° F -46° C	5,800	94V-0	30	2 × 10 ⁸ Rads	Excellent	UL2043 Grade 1 ASTM D-3159 Type 1
Halar® (CTH)	284° F 140° C	-50° F -46° C	6,100	94V-0	52	2 × 10 ⁸ Rads	Excellent	ASTM D-3275 Type 3 FDA CRF177.1380

* Elevated temperatures, over time, will affect materials' properties such as tensile strength, stiffness, elongation and appearance.

FCI BURNDY® recommends the evaluation of cable ties in the actual application to determine the suitability of the tie for that application.

Tefzel® is a registered trademark of E.I. DuPont Corporation. Halar® is a registered trademark of Ausimont Chemical Co.

Throughout the catalog you will notice blue highlighted items. These are the most frequently ordered BURNDY® Products.

Material Performance Guide

Selection	Nylon 6/6 General Purpose	Nylon 6/6 Heat Stab.	Nylon 6/6 UV Stab.	Nylon 6/6 2% Carbon UV Stab.	Nylon 6/6 Flame Ret. V0	Nylon 6/6 High Impact	Poly- propylene	Nylon 12 UV Stab.	Tefzel®	Halar®
Tensile Strength	8	8	8	9	7	8	2	4	5	5
High Temp.	2	3	2	2	2	2	2	1	10	10
Flammability	5	5	5	5	10	2	2	2	10	10
UV Resistance	1	1	5	8	1	2	5	3	10	10
Radiation	3	3	3	3	3	3	6	3	10	10
Chemical	6	6	6	6	6	6	8	8	10	10
— Hydrocarbons	8	8	8	8	8	8	6	8	10	10
— Chlorinated	6	6	6	6	6	6	3	8	10	10
— Hydrocarbons	2	2	2	2	2	2	8	5	10	10
— Acids-Bases	6	6	6	6	6	6	8	6	10	10
— Salts	3	3	3	3	3	3	10	8	10	10
Relative Cost	Low	Low	Med.	Med.	Med.	Med.	Med.	Med.	High	High

1 = Least Recommended 10 = Most Recommended

The following chart is meant to help you understand FCI BURNDY's cable tie catalog numbering system. Not every cable tie is available in every listed option. See below Catalog Numbering System Charts or con-

tact FCI BURNDY® Customer Service for more information.

Gray bars contain catalog number examples.

Type	Tensile	Bundle Dia.	Feature	Package	Color
CT	50	175		C	
BET = BURNDY® Extended Tie	18 = 18 lbs. 30 = 30 lbs. 40 = 40 lbs.	075 = 3/4" 087 = 7/8" 100 = 1"	EPR = Extended Pawl Releasable ID = Single Head ID ID2 = Double Head ID ID3 = Triple Head ID	V = 5 X = 10 Q = 25 L = 50	1 = Brown 2 = Red 3 = Orange 4 = Yellow
CT = Nylon 6/6 Standard	50 = 50 lbs. 120 = 120 lbs. 175 = 175 lbs.	125 = 1-1/4" 137 = 1-3/8" 150 = 1-1/2"	FL = ID Flag MH4 = Mounting Hole #4 MH6 = Mounting Hole #6 MH8 = Mounting Hole #8 MH10 = Mounting Hole #10 MH14 = Mounting Hole #14	C = 100 B = 250 D = 500 M = 1000	5 = Green 6 = Blue 7 = Purple 8 = Gray None = Natural 10 = White 11 = Telco Gray
CTAS = Aerial Support	250 = 250 lbs.	175 = 1-3/4" 200 = 2" 250 = 2-1/2"	PM = Push Mount Tie PML = Push Mount Tie w/Louvers PMW = Push Mount Tie w/Wing R = Releasable Tie LP = Low Profile Tie PS = Positive Stop		0 = UV Black ¹ 00 = UV Black ² 02 = Red 20 = Black
CTH = Halar®		300 = 3" 400 = 4" 500 = 5"			
CTZ = Tefzel®		600 = 6" 700 = 7" 800 = 8" 900 = 9" 1000 = 10" 1100 = 11"			
CTHS = Nylon 6/6 Heat Stabilized		1200 = 12" 1300 = 13" 1400 = 14" 1500 = 15" 1600 = 16"			
CTV = Nylon 6/6 Flame Retardant UL94V-0					
CTPP = Polypropylene					

¹Material: Nylon 6/6 — UV Stabilized

²Material: Nylon 6/6 — 2% Carbon UV Stabilized (Mil. Spec.)

Type	Tensile	Bundle Dia.	Package
CTSS	100	200	C
CTSS = 304 Stainless Steel	100 = 100 lbs. 250 = 250 lbs.	Same as above	Same as above

Type	Size	Mount Method	Feature	Quantity	Color
CTB	125	RA	4	C	0
CTB = Cable Tie Base	075 = 3/4" 125 = 1-1/4" 150 = 1-1/2"	RA = Rubber Adhesive AA = Acrylic Adhesive S = Screw Mounted	2 = 2 way 4 = 4 way	L = 50 C = 100 D = 500 M = 1000	0 = UV Black

Military Specification UNIRAP™ Cable Ties

The FCI BURNDY® cable ties shown below meet the requirements of SAE AS23190A (formerly MIL-S-23190) in accordance with specification MS3367, MS3368, and QPL-23190.

Natural Cable Ties

Mil Spec	Distributor Pack Catalog Number	Bulk Pack Catalog Number	Description (Bundle Dia. - Tensile Strength)
MS3367-1-9	CT50175C	CT50175M	1.75" - 50 lbs.
MS3367-2-9	CT50400C	CT50400M	4" - 50 lbs.
MS3367-3-9	CT120400L	CT120400D	4" - 120 lbs.
MS3367-3-9	CT175400Q	N/A	4" - 175 lbs.
MS3367-3-9	CT175600Q	N/A	6" - 175 lbs.
MS3367-4-9	CT18075C	CT18075M	.75" - 18 lbs.
MS3367-5-9	CT30125C	CT30125M	1.25" - 30 lbs.
MS3367-6-9	CT120900L	CT120900D	9" - 120 lbs.
MS3367-6-9	CT175900Q	N/A	9" - 175 lbs.
MS3367-7-9	CT50300C	CT50300M	3" - 50 lbs.

G-5

UV Resistant Black Cable Ties

Mil Spec	Distributor Pack Catalog Number	Bulk Pack Catalog Number	Description (Bundle Dia. - Tensile Strength)
MS3367-1-0	CT50175C00	CT50175M00	1.75" - 50 lbs.
MS3367-2-0	CT50400C00	CT50400M00	4" - 50 lbs.
MS3367-3-0	CT120400L00	CT120400D00	4" - 120 lbs.
MS3367-3-0	N/A	N/A	4" - 175 lbs.
MS3367-3-0	CT175600Q00	N/A	6" - 175 lbs.
MS3367-4-0	CT18075C00	CT18075M00	.75" - 18 lbs.
MS3367-5-0	CT30125C00	CT30125M00	1.25" - 30 lbs.
MS3367-6-0	CT120900L00	CT120900D00	9" - 120 lbs.
MS3367-6-0	CT175900Q00	N/A	9" - 175 lbs.
MS3367-7-0	CT50300C00	CT50300M00	3" - 50 lbs.

Natural Identification Cable Ties

Mil Spec	Distributor Pack Catalog Number	Bulk Pack Catalog Number	Description (Bundle Dia. - Tensile Strength)
MS3368-1-A	CT50175IDC	N/A	1.75" - 50 lbs.
MS3368-2-A	CT50400IDC	N/A	4" - 50 lbs.
MS3368-3-C	CT50175ID2L	N/A	1.75" - 50 lbs. Double Strap
MS3368-4-D	CT50175ID3L	N/A	1.75" - 50 lbs. Triple Strap
MS3368-5-E	CT18075IDC	N/A	.75" - 18 lbs.

Throughout the catalog you will notice blue highlighted items. These are the most frequently ordered BURNDY® Products.

UNIRAP™

STANDARD CABLE TIES

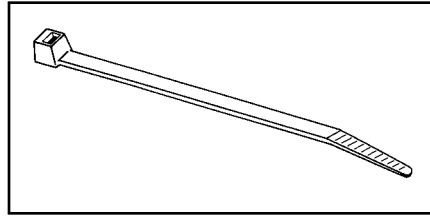

18 Lb. Minimum Tensile Strength

Standard Package Catalog Number	Material	Maximum Bundle Diameter Inches [mm]	Minimum Tensile Strength Lbs. (N)	Length Inches [mm]	Width Inches [mm]	Installation Tool	Tool Setting	Bulk Package Catalog Number
CT18075C	Natural Nylon 6/6	.75 [19]	18 (80)	4.00 [102]	.10 [2.5]	TWT1, MK7	Mini	CT18075M
CT18075C0	Black Nylon 6/6 UV							
CT18125C	Natural Nylon 6/6	1.25 [32]		5.67 [144]				CT18125M
CT18125C0	Black Nylon 6/6 UV							CT18125M0
CT18200C	Natural Nylon 6/6	2.00 [51]		8.00 [203]				CT18200M
CT18200C0	Black Nylon 6/6 UV							CT18200M0

G-6

30 Lb. Minimum Tensile Strength



Standard Package Catalog Number	Material	MAXIMUM BUNDLE DIAMETER In. [mm]	MINIMUM TENSILE STRENGTH Lbs. (N)	LENGTH In. [mm]	WIDTH In. [mm]	INSTALLATION TOOL	TOOL SETTING	BULK PACKAGE CATALOG NUMBER
CT30125C	Natural Nylon 6/6	1.25 [32]	30 (133)	6.00 [152]	.14 [3.6]	TWT1, MK7	Intermediate	CT30125M
CT30125C0	Black Nylon 6/6 UV							

40 Lb. Minimum Tensile Strength



Standard Package Catalog Number	Material	Maximum Bundle Diameter Inches [mm]	Minimum Tensile Strength Lbs. (N)	Length Inches [mm]	Width Inches [mm]	Installation Tool	Tool Setting	Bulk Package Catalog Number
CT40200C	Natural Nylon 6/6	2.00 [51]	40 (178)	8.50 [216]	.15 [3.8]	TWT1, MK7	Intermediate	CT40200M
CT40200C0	Black Nylon 6/6 UV							
CT40300C	Natural Nylon 6/6	3.00 [76]		11.50 [292]				CT40300M
CT40300C0	Black Nylon 6/6 UV							CT40300M0
CT40400C	Natural Nylon 6/6	4.00 [102]		14.50 [368]				CT40400M
CT40400C0	Black Nylon 6/6 UV							CT40400M0

50 Lb. Minimum Tensile Strength



Standard Package Catalog Number	Material	Maximum Bundle Diameter Inches [mm]	Minimum Tensile Strength Lbs. (N)	Length Inches [mm]	Width Inches [mm]	Installation Tool	Tool Setting	Bulk Package Catalog Number
CT50175C	Natural Nylon 6/6	1.75 [44]	50 (222)	8.00 [203]	.18 [4.6]	TWT1, MK7	Standard	CT50175M
CT50175C0	Black Nylon 6/6 UV							
CT50300C	Natural Nylon 6/6	3.00 [76]		11.75 [298]				CT50300M
CT50300C0	Black Nylon 6/6 UV							CT50300M0
CT50400C	Natural Nylon 6/6	4.00 [102]		15.50 [394]				CT50400M
CT50400C0	Black Nylon 6/6 UV							CT50400M0

Throughout the catalog you will notice blue highlighted items. These are the most frequently ordered BURNDY® Products.

UNIRAP™

STANDARD CABLE TIES

(Continued)

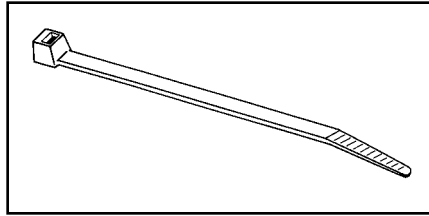

120 Lb. Minimum Tensile Strength

Standard Package Catalog Number	Material	Maximum Bundle Diameter Inches [mm]	Minimum Tensile Strength Lbs. (N)	Length Inches [mm]	Width Inches [mm]	Installation Tool	Tool Setting	Bulk Package Catalog Number
CT120200L	Natural Nylon 6/6	2.00 [51]	120 (534)	8.87 [226]	.30 [7.6]	TWT2, MK9	Standard	CT120200D
CT120200LO	Black Nylon 6/6 UV			11.87 [302]				CT120200DO
CT120300L	Natural Nylon 6/6	3.00 [76]		15.25 [387]				CT120300D
CT120300LO	Black Nylon 6/6 UV			29.75 [776]				CT120300DO
CT120400L	Natural Nylon 6/6	4.00 [102]						CT120400D
CT120400LO	Black Nylon 6/6 UV							CT120400DO
CT120900L	Natural Nylon 6/6	9.00 [229]						
CT120900LO	Black Nylon 6/6 UV							

G-7

175 Lb. Minimum Tensile Strength



Standard Package Catalog Number	Material	Maximum Bundle Diameter Inches [mm]	Minimum Tensile Strength Lbs. (N)	Length Inches [mm]	Width Inches [mm]	Installation Tool	Tool Setting	Bulk Package Catalog Number
CT175400Q	Natural Nylon 6/6	4.00 [102]	175 (778)	15.00 [381]	.35 [8.9]	TWT2, MK9	Heavy	
CT175400QO	Black Nylon 6/6 UV			21.00 [533]				
CT175600Q	Natural Nylon 6/6	6.00 [152]		32.00 [813]				
CT175600QO	Black Nylon 6/6 UV			36.00 [914]				
CT175900Q	Natural Nylon 6/6	9.00 [229]		52.00 [1321]				
CT175900QO	Black Nylon 6/6 UV							
CT1751100Q	Natural Nylon 6/6	11.00 [279]						
CT1751100QO	Black Nylon 6/6 UV							
CT1751400Q	Natural Nylon 6/6	14.00 [356]						
CT1751400QO	Black Nylon 6/6 UV							

250 Lb. Minimum Tensile Strength



Standard Package Catalog Number	Material	Maximum Bundle Diameter Inches [mm]	Minimum Tensile Strength Lbs. (N)	Length Inches [mm]	Width Inches [mm]	Installation Tool	Tool Setting	Bulk Package Catalog Number
CT250600Q	Natural Nylon 6/6	6.00 [152]	250 (1112)	23.00 [584]	.50 [12.7]	TWT2, MK9	Heavy	
CT250600QO	Black Nylon 6/6 UV			29.00 [737]				
CT250800Q	Natural Nylon 6/6	8.00 [203]		35.00 [889]				
CT250800QO	Black Nylon 6/6 UV			40.00 [1016]				
CT2501000Q	Natural Nylon 6/6	10.00 [254]						
CT2501000QO	Black Nylon 6/6 UV							
CT2501200Q	Natural Nylon 6/6	12.00 [305]						
CT2501200QO	Black Nylon 6/6 UV							

Throughout the catalog you will notice blue highlighted items. These are the most frequently ordered BURNDY® Products.

UNIRAP™

RELEASABLE CABLE TIES

Perfect for prototype construction, releasable cable ties are ideal for temporary installations. Releasable ties are also good for applications where service requires adding or subtracting wires from an existing wire bundle.

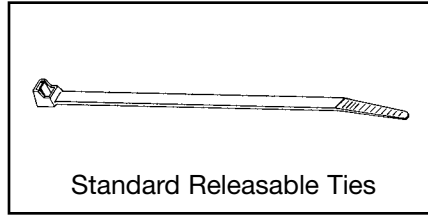

Standard Releasable Ties

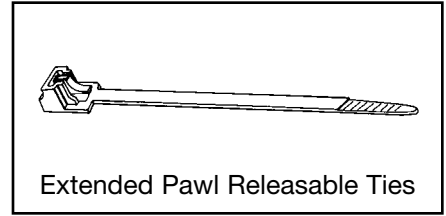

Extended Pawl Releasable Ties

Standard Releasable Cable Ties

Standard Package Catalog Number	Material	Maximum Bundle Diameter Inches [mm]	Minimum Tensile Strength Lbs. (N)	Length Inches [mm]	Width Inches [mm]
CT40200RC	Natural Nylon 6/6	2.00 [51]	40 (178)	8.50 [216]	.16 [4]
CT40200RC0	Black Nylon 6/6 UV				
CT50137RC	Natural Nylon 6/6	1.38 [35]	50 (222)	6.50 [165]	.18 [4.6]
CT50137RC0	Black Nylon 6/6 UV				
CT50400RC	Natural Nylon 6/6	4.00 [102]		15.50 [394]	
CT50400RC0	Black Nylon 6/6 UV				

Extended Pawl Releasable Cable Ties

Standard Package Catalog Number	Material	Maximum Bundle Diameter Inches [mm]	Minimum Tensile Strength Lbs. (N)	Length Inches [mm]	Width Inches [mm]
CT50137EPRC	Natural Nylon 6/6	1.38 [35]	50 (222)	5.50 [140]	.291 [7.4]
CT50137EPRC0	Black Nylon 6/6 UV				
CT50250EPRC	Natural Nylon 6/6	2.50 [64]		9.80 [249]	
CT50250EPRC0	Black Nylon 6/6 UV				

Heavy Duty Releasable Cable Ties

Standard Package Catalog Number	Material	Maximum Bundle Diameter Inches [mm]	Minimum Tensile Strength Lbs. (N)	Length Inches [mm]	Width Inches [mm]
CT250200RQ	Natural Nylon 6/6	2.00 [51]	250 (1112)	9.00 [229]	.50 [12.7]
CT250200RQ0	Black Nylon 6/6 UV				
CT250500RQ	Natural Nylon 6/6	5.00 [127]		20.00 [508]	
CT250500RQ0	Black Nylon 6/6 UV				
CT250600RQ	Natural Nylon 6/6	6.00 [152]		23.00 [584]	
CT250600RQ0	Black Nylon 6/6 UV				
CT250800RQ	Natural Nylon 6/6	8.00 [203]		29.00 [737]	
CT250800RQ0	Black Nylon 6/6 UV				
CT2501000RQ	Natural Nylon 6/6	10.00 [254]		35.00 [889]	
CT2501000RQ0	Black Nylon 6/6 UV				
CT2501200RQ0	Black Nylon 6/6 UV	12.00 [305]		40.00 [1016]	

Throughout the catalog you will notice blue highlighted items. These are the most frequently ordered BURNDY® Products.

G-8

UNIRAP™

IDENTIFICATION CABLE TIES

Identification cable ties are used in both bundling and identifying wire groups at the same time.

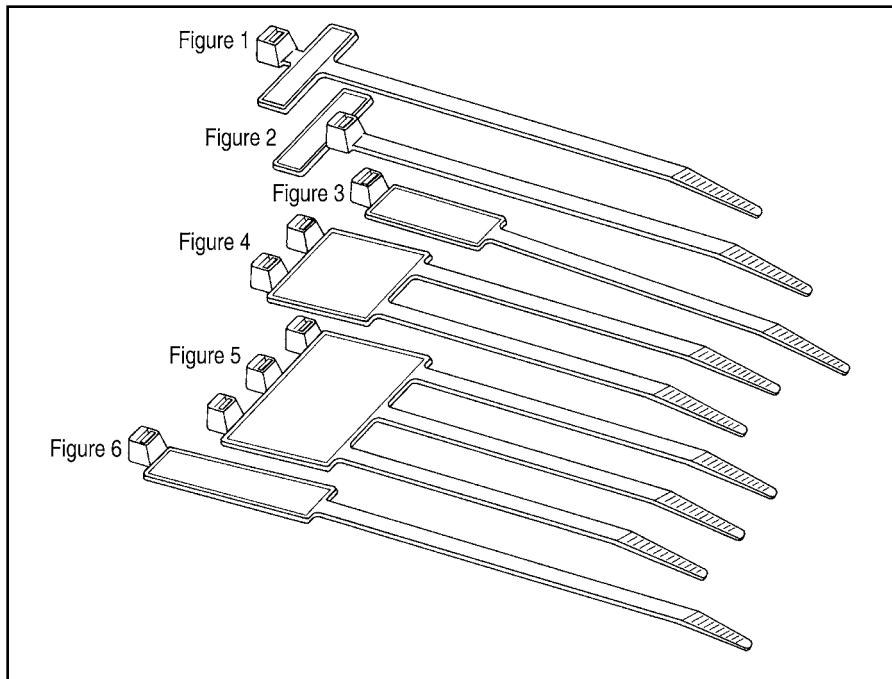

Standard Package Catalog Number	Material	Fig. No.	Marking Pad Size Inches [mm]	Maximum Bundle Diameter Inches [mm]	Minimum Tensile Strength Lbs. (N)	Length Inches [mm]	Width Inches [mm]	Installation Tool & (Setting)
CT18075IDC	Natural Nylon 6/6	1	1 × 19/64 [25.4 × 7.5]	.75 [19]	18 (80)	4.00 [102]	.10 [2.5]	MK7 (MIN)
CT18075FLC		2	13/16 × 5/16 [20.5 × 7.9]			4.25 [108]		
CT50175IDC		3	1 × 7/16 [25.4 × 11.1]	1.75 [44]	50 (222)	8.00 [203]	.18 [4.6]	MK7 (STD)
CT50175ID2L		4	1-11/16 × 5/16 [29.8 × 23.8]					
CT50175ID3L		5	1-13/16 × 15/16 [46 × 23.8]					
CT50400IDC		6	1/2 × 2-1/8 [12.7 × 54]	4.00 [107]	15.00 [381]			

UNIRAP™

MOUNTING HOLE CABLE TIES

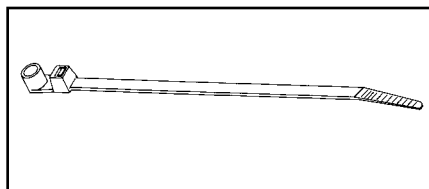

Standard Package Catalog Number	Material	Screw Size	Maximum Bundle Diameter Inches [mm]	Minimum Tensile Strength Lbs. (N)	Length Inches [mm]	Width Inches [mm]	Installation Tool & (Setting)	Bulk Package Catalog Number
CT18075MH4C	Natural Nylon 6/6	#4 (M2,5)	.75 [19]	18 (80)	4.25 [108]	.10 [2.5]	MK7 (MIN)	CT18075MH4M
CT18075MH4CO	Black Nylon 6/6 UV							—
CT30125MH8C	Nylon 6/6	#8 (M4)	1.25 [32]	30 (133)	6.25 [159]	.14 [3.6]	MK7 (INT)	—
CT30125MH8CO	Nylon 6/6 UV							—
CT50175MH10C	Nylon 6/6	#10 (M5)	1.75 [44]	50 (222)	8.50 [216]	.18 [4.6]	MK7 (STD)	CT50175MH10M
CT50175MH10CO	Nylon 6/6 UV							CT50175MH10M0
CT50400MH10C	Nylon 6/6 GP							—
CT50400MH10CO	Nylon 6/6 UV	#10 (M5)	4.00 [102]	50 (222)	16.00 [406]		MK7 (STD)	CT50400MH10M0
CT120400MH14L	Nylon 6/6							—
CT120400MH14LO	Nylon 6/6 UV	1/4" (M6)	4.00 [102]	120 (534)	16.25 [413]	.30 [7.6]	MK9 (STD)	CT120400MH14D0

Throughout the catalog you will notice blue highlighted items. These are the most frequently ordered BURNDY® Products.

UNIRAP™

HALAR® TIES

Halar® ties meet NEC regulations and can be used in applications where low smoke and low flame are a concern, as in air handling spaces. The raw material used to manufacture FCI BURNDY® Halar® cable ties is UL 94V-0 rated. These ties come in a distinct color of red for easy identification.

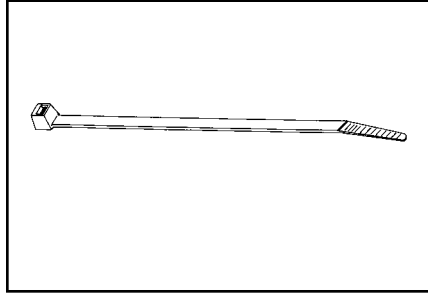

Halar® Cable Ties

Standard Package Catalog Number	Material	Maximum Bundle Diameter Inches [mm]	Minimum Tensile Strength Lbs. (N)	Length Inches [mm]	Width Inches [mm]	Installation Tool	Tool Setting	Bulk Package Catalog Number
CTH18075C	Halar	.75 [19]	18 (80)	4.00 [102]	.10 [2.5]	MK7	Mini	CTH18075M
CTH30200C		2.00 [51]	30 (133)	8.00 [203]	.14 [3.6]		Intermediate	—
CTH50175C		1.75 [44]	50 (222)	8.00 [203]	.18 [4.6]	MK9	Standard	CTH50175M
CTH120400L		4.00 [102]	120 (534)	15.25 [387]	.18 [4.6]			—

UNIRAP™

TEFZEL® TIES

Tefzel® ties provide excellent protection against radiation, ultraviolet light, and a wide range of chemicals. It is also rated for low outgassing applications. FCI BURNDY® Tefzel® ties offer temperature stability to 150° C and come in a standard color of blue for easy identification.

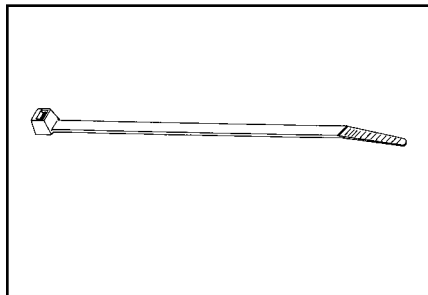

Tefzel® Cable Ties

Standard Package Catalog Number	Material	Maximum Bundle Diameter Inches [mm]	Minimum Tensile Strength Lbs. (N)	Length Inches [mm]	Width Inches [mm]	Installation Tool	Tool Setting	Bulk Package Catalog Number
CTZ18075C	Tefzel	.75 [19]	18 (80)	4.00 [102]	.10 [2.5]	MK7	Mini	—
CTZ30200C		2.00 [51]	30 (133)	8.00 [203]	.14 [3.6]		Intermediate	—
CTZ50175C		1.75 [44]	50 (222)	8.00 [203]	.18 [4.6]	MK9	Standard	—
CTZ120400L		4.00 [102]	120 (534)	15.25 [387]	.18 [4.6]			CTZ120400D

Throughout the catalog you will notice blue highlighted items. These are the most frequently ordered BURNDY® Products.

G-10

TYPE TFV-B

HOOK AND LOOP STRAPS

Reusable and flexible BURNDY® Hook and Loop Straps are a unique self-gripping fastening system.

These ties are specifically used on fiberoptic applications.

The TFV-V2 flame retardant straps are UL Listed Wire Positioning Devices (ZODZ), UL94-V2 rated for use in air handling spaces in accordance with the NEC section 300-22 (c) and (d). Perfect for plenum areas.

25 straps are conveniently packaged in each polybag.

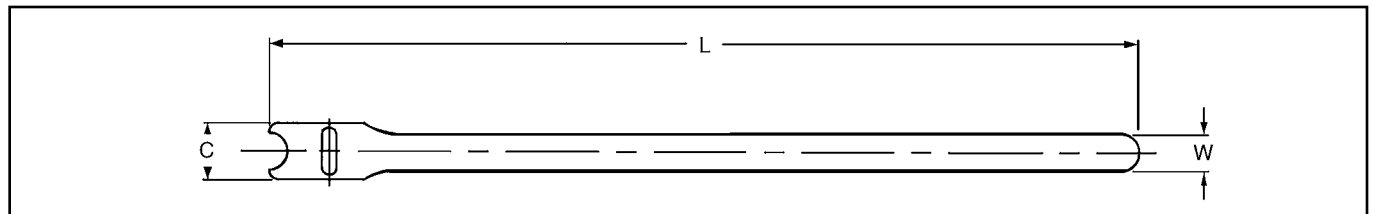

Catalog Number	Product Description	C	L	W	T	Maximum Bundle Dia.	Avg. Sheer (PSI)	Avg. Peel (PIW)	Pkg. Qty.
TFV3B12V2**	VELCRO® hook and loop strap, 3/4" × 12", Black, 25pk	0.75"	12.00"	.50"	.09"	3.0"	29	.6	*1
TFV3B18V2**	VELCRO® hook and loop strap, 3/4" × 18", Black, 25pk	0.75"	18.00"	.50"	.09"	5.0"	29	.6	*1
TFV3B6V2**	VELCRO® hook and loop strap, 3/4" × 6", Black, 25pk	0.75"	6.00"	.50"	.09"	1.0"	23	.6	*1
TFV3BLU12	VELCRO® hook and loop strap, 3/4" × 12", Royal Blue, 25pk	0.75"	12.00"	.50"	.09"	3.0"	23	.5	*1
TFV3BLU18	VELCRO® hook and loop strap, 3/4" × 18", Royal Blue, 25pk	0.75"	18.00"	.50"	.09"	5.0"	23	.5	*1

* Straps sold by the package, quantity 1 package equals 25 straps.

** UL94-V2 listed.

VELCRO® is a registered trademark of Velcro USA, Inc.

G-11

Throughout the catalog you will notice blue highlighted items. These are the most frequently ordered BURNDY® Products.

MOUNTING BASES

FCI BURNDY® offers a wide variety of mounting bases suited for many applications. Mounting bases are used in conjunction with cable ties to stabilize and secure wire bundles, both indoors and outdoors. Mounting bases can be secured to a surface using rubber based adhesive, acrylic adhesive, or also can be screw mounted.

FCI BURNDY's 4-way mounting bases are available in four sizes to accommodate CT18 through CT50 series cable ties. Insertion of ties can be made from all sides. Each mount may be secured with two screws, with adhesive backing, or both, for ease of application and stability. For applications where higher temperatures, certain chemicals, or UV radiation are a concern and an adhesive is the preferred method for securing, the acrylic adhesive 4-way mounting bases are recommended.

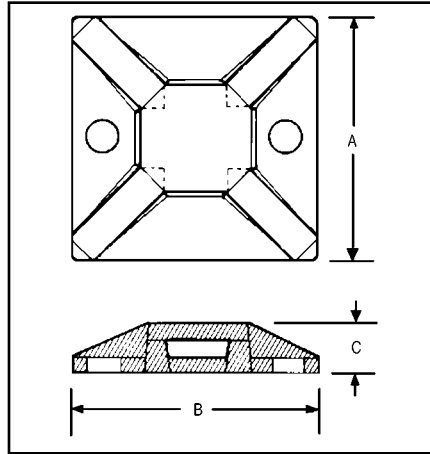

The 2-way mounting bases may be secured with one screw, with adhesive backing, or both, and allow ties to be inserted from two sides.

4-Way



Catalog Number	Mounting Method	Maximum Tie Slot Width	Dimension A	Dimension B	Dimension C	Pkg. Qty.
CTB075S4C	#4 Screw	.14"	.75"	.75"	.15"	100
CTB075AA4C	Acrylic Adhesive	.14"	.75"	.75"	.15"	100
CTB075RA4C	Rubber Adhesive	.14"	.75"	.75"	.15"	100
CTB075RA4M	Rubber Adhesive	.14"	.75"	.75"	.15"	1000
CTB125S4C	#8 Screw	.20"	1.125"	1.125"	.19"	100
CTB125AA4C	Acrylic Adhesive	.20"	1.125"	1.125"	.19"	100
CTB125RA4C	Rubber Adhesive	.20"	1.125"	1.125"	.19"	100
CTB125RA4L	Rubber Adhesive	.20"	1.125"	1.125"	.19"	50
CTB125RA4D	Rubber Adhesive	.20"	1.125"	1.125"	.19"	500
CTB150S4B	#8 Screw	.35"	1.5"	1.5"	.25"	250
CTB150AA4C	Acrylic Adhesive	.35"	1.5"	1.5"	.25"	100
CTB150RA4C	Rubber Adhesive	.35"	1.5"	1.5"	.25"	100
CTB150RA4B	Rubber Adhesive	.35"	1.5"	1.5"	.25"	250

All bases listed above are natural. UV Black mounting bases are also available in nearly every size. Insert "0" after the part number.

2-Way

Catalog Number	Mounting Method	Maximum Tie Slot Width	Dimension A	Dimension B	Dimension C	Pkg. Qty.
CTB125S2C	#6 Screw	.18"	1.125"	1.125"	.21"	100
CTB125RA2C	Rubber Adhesive	.18"	1.125"	1.125"	.21"	100

All bases listed above are natural. UV Black mounting bases are also available in nearly every size. Insert "0" after the part number.

Throughout the catalog you will notice blue highlighted items. These are the most frequently ordered BURNDY® Products.

G-12

CABLE HANGERS

Cable Hangers provide a contact area range of 1/2" to 3/8" in width. All contact edges have a full radius for product protection, and sizes are clearly marked on each clamp.

Cable Hangers are injection molded. Available in white nylon 6/6 and black nylon 6/6.

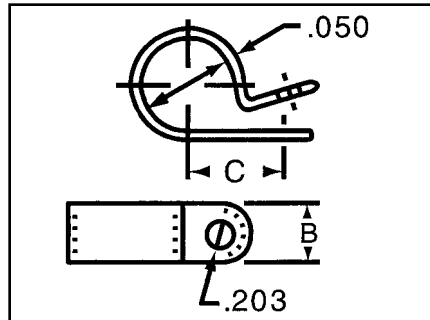

Catalog Number	Mounting Screw	Maximum Bundle	Dimension B (Width)	Dimension C (Mount Hole Centers)	Pkg. Qty.
CH2C	#10 Screw	.125"	.375"	.329"	100
CH2M	#10 Screw	.125"	.375"	.329"	1000
CH3C	#10 Screw	.187"	.375"	.430"	100
CH3M	#10 Screw	.187"	.375"	.430"	1000
CH4C	#10 Screw	.25"	.375"	.410"	100
CH4M	#10 Screw	.25"	.375"	.410"	1000
CH5C	#10 Screw	.312"	.375"	.495"	100
CH5M	#10 Screw	.312"	.375"	.495"	1000
CH6C	#10 Screw	.375"	.375"	.595"	100
CH6M	#10 Screw	.375"	.375"	.595"	1000
CH7C	#10 Screw	.437"	.375"	.574"	100
CH7M	#10 Screw	.437"	.375"	.574"	1000
CH8C	#10 Screw	.5"	.375"	.605"	100
CH8M	#10 Screw	.5"	.375"	.605"	1000
CH9C	#10 Screw	.563"	.375"	.606"	100
CH9M	#10 Screw	.563"	.375"	.606"	1000
CH10C	#10 Screw	.625"	.375"	.606"	100
CH10M	#10 Screw	.625"	.375"	.606"	1000
CH11C	#10 Screw	.625"	.5"	.655"	100
CH11M	#10 Screw	.625"	.5"	.655"	1000
CH12C	#10 Screw	.750"	.5"	.78"	100
CH12M	#10 Screw	.750"	.5"	.78"	1000
CH14C	#10 Screw	.875"	.5"	.845"	100
CH14M	#10 Screw	.875"	.5"	.845"	1000
CH16C	#10 Screw	1"	.5"	.91"	100
CH16M	#10 Screw	1"	.5"	.91"	1000
CH18C	#10 Screw	1.12"	.5"	.97"	100
CH18M	#10 Screw	1.12"	.5"	.97"	1000
CH24L	#10 Screw	1.5"	.5"	1.19"	50
CH24C	#10 Screw	1.5"	.5"	1.19"	100

All hangers listed above are natural. UV Black cable hangers are also available in nearly every size. Insert "0" after the part number.

G-13

Throughout the catalog you will notice blue highlighted items. These are the most frequently ordered BURNDY® Products.

UNIRAP™

STAINLESS STEEL TIES

FCI BURNDY's Stainless Steel ties are designed to secure hoses, cables, poles, pipes, and more when harsh environmental conditions may adversely affect the bundling application. Used where corrosion, vibration, weathering, radiation, and temperature extremes are a concern, FCI BURNDY's Stainless Steel ties can be used in virtually any indoor, outdoor, and underground application.

FCI BURNDY® Stainless Steel ties are made from Grade 304 Stainless Steel. This tie is designed with a low profile clamping bearing head with fully adjustable strap accommodating many bundle diameters.



Features

- Smooth, rounded edges help ensure safe, efficient handling.
- Ergonomically designed installation tool consistently tensions and cuts off ties leaving flush edges.
- Flame retardant and non-toxic for applications where safety from fire is critical.

Standard Package Catalog Number	Material	Maximum Bundle Diameter Inches [mm]	Minimum Tensile Strength Lbs. (N)	Length Inches [mm]	Head Width Inches [mm]	Strap Width Inches [mm]	Installation Tool & (Setting)
CTSS100200C	304 SS	1.96 [50]	150 (670)	7.90 [201]	.26 [4.6]	.18 [4.6]	MK9SST (INT)
CTSS100400C		3.93 [100]		14.30 [363]			
CTSS100600C		5.90 [150]		20.50 [521]			
CTSS100800C		7.87 [200]		26.80 [681]			
CTSS1001000C		9.84 [250]		33.00 [838]			
CTSS250200L	304 SS	1.96 [50]	250 (1112)	7.90 [201]	.39 [9.8]	.31 [7.9]	MK9SST (STD)
CTSS250400L		3.93 [100]		14.30 [363]			
CTSS250600L		5.90 [150]		20.50 [521]			
CTSS250800L		7.87 [200]		26.80 [681]			

Throughout the catalog you will notice blue highlighted items. These are the most frequently ordered BURNDY® Products.

G-14

CABLE TIE TOOLS

Ergonomics and the prevention of repetitive motion injuries, coupled with the need to continually improve assembly efficiencies and procedures, are a major concern with most cable tie users. FCI BURNDY® cable tie tools effectively address both issues. FCI BURNDY® has world class cable tie tools to complement its line of high quality cable ties. FCI BURNDY® cable tie tools are truly state-of-the-art in both design and performance.

FCI BURNDY® tools make it easier for operators to install cable ties, while maintaining correct tension and flush cut-off. Worker safety is further enhanced as the tools can eliminate the sharp edges of a cut-off cable tie.



G-15

Catalog Number	Description	For Use On
MK7	Adjustable Tensioning Tool for Width .10" to .19"	CT18 - CT50 Series Ties
MK9	Adjustable Tensioning Tool for Width .19" to .35"	CT18 - CT250 Series Ties
TWT1	Non-adjustable Tensioning Tool for Width .10" to .19" Twist & Cut	CT18 - CT50 Series Ties
TWT2	Non-adjustable Tensioning Tool for Width .19" to .35" Twist & Cut	CT120 - CT175 Series Ties

Throughout the catalog you will notice blue highlighted items. These are the most frequently ordered BURNDY® Products.