



Product Specification

10Gbit/s X2 LRM Transponder (TRP10GDL0603, TRP10GDL06CA)

General Description and Applications

The TRP10GDL0603 is a highly integrated, serial optical transponder module for high-speed, 10Gbit/s data transmission applications. The module is fully compliant to IEEE 802.3aq-2006 standard for Ethernet, making it ideally suited for 10 GbE datacom (rack-to-rack, client interconnection) applications. Designed for distances of up to 220m over legacy multimode fibers, the transponder module comprises a transmitter with a directly modulated uncooled 1310nm DFB laser, a receiver with a PIN photodiode, a XAUI-Attachment Interface, an integrated Coder / Decoder and multiplexer / demultiplexer (SERDES: Serializer / Deserializer). The transponder operates within a wide case temperature range of 0°C to +70°C and offers optimum heat dissipation and excellent electromagnetic shielding which enables high port densities for 10 GbE systems. A 70 pin electrical connector and a duplex SC connector optical interface assure that connectivity is compliant to the X2 and XENPAK MSA



Standard	Description	Nominal Baud Rate	Unit
IEEE 802.3aq-2006	10 GBASE-LRM	10.3125	GBd

FEATURES & BENEFITS

- Support X2 MSA Rev. 2.0b
- Support IEEE 802.3aq-2006 10GBASE-LRM at 10.3125Gbit/s (TRP10GDP0303)
- Typical transmission distance up to 220 m over MMF
- Low Power Consumption 3.2 W (typ.)
- 0°C - 70°C case operating temperature range
- Laser Class 1 IEC / CDRH compliant
- SC duplex connector
- Uncooled 1310nm DFB Laser
- Hot pluggable 70-pin connector with XAUI electrical interface
- Management and control via MDIO 2-wire interface
- Complaint with the EU RoHS 6 Environmental requirements

Absolute Maximum Ratings

Rating	Conditions/Remark	Symbol	Min	Max	Units
Storage Ambient Temperature	non condensing	ϑ_{stg}	-40	+85	°C
Powered Case Temperature	non condensing	ϑ_c	-10	+75	°C
Adaptable Power Supply (APS)	Voltage @ Pin APS Sense	$V_{APSSense}$	-0.3	1.5	V
Supply Voltage 3.3V Rail		V_{CC3}	-0.3	3.8	V
Supply Voltage 5V Rail		V_{CC5}	-0.5	7.0	V
Input Voltage Low Speed Signals	RESET, TxOn/Off, PRTADR4..0	V_I		tbd	V
Clamp Currents Low Speed Signals	RESET, TxOn/Off, PRTADR4..0 V<0V	I_{IK}		tbd	mA
LASI Voltage		V_Q	-0.3	1.5	V
LASI Sink Current	Continuous Sink Current	I_{QL}		20	mA
XAUI Input Level		V_{IXAUI}	-0.3	1.8	V
Differential XAUI Input Amplitude		$ V_{IDXAUI} $		tbd	mV
Optical Receiver Input Power	Average Receiver Input Power	P_{Rx}		+4	dBm
Static Discharge Voltage	MIL STD 883 Method 3015.1			500	V

Any stress beyond the maximum ratings can result in permanent damage. The device specifications are guaranteed only under the recommended operating conditions.

Recommended Operating Conditions

Parameter	Conditions / Remark	Symbol	Min	Typ	Max	Units
Operating Case Temperature Range		ϑ_{Case}	0		+70	°C
APS Voltage ¹⁾²⁾		V_{APS}	0.95	1.0	1.05	V
Power Supply Voltage @ 3.3V		V_{CC3}	3.135	3.3	3.465	V
Power Supply Voltage @ 5.0V		V_{CC5}	4.75	5.00	5.25	V

- 1) The device is supposed to operate in the APS control environment described and specified in the XENPAK-MSA (page 22 to 24 of Revision 3.0). In this environment the *APS-Sense Voltage* requirements will be automatically satisfied if *APS-Feedback Voltage* is within its recommended range. The operating *APS-Sense Voltage* is for informational purposes and is subject to be changed without further notice.
- 2) A more detailed description on the APS control circuit can also be found on page **Fout! Bladwijzer niet gedefinieerd..**

Electrical Characteristics

<i>Parameter</i>	<i>Conditions</i>	<i>Symbol</i>	<i>Min</i>	<i>Typ</i>	<i>Max</i>	<i>Units</i>
5V Supply Current	$P_{Rx} = 0 \dots 0.5 \dots 1.125\text{mW}$	I_{VCC5}	0.38	2	3	mA
3.3V Supply Current	RESET=H, TxOn/Off = H	I_{VCC3}	310	390	590	mA
APS Supply Current	$V_{Feedback} = 785 \dots 800 \dots 812\text{mV}$	I_{VCCAPS}	550	1950	2200	mA
APS-Input Capacitance		C_{APS}		tbd		μF

XAUI - Interface

XAUI Input Characteristics

<i>Parameter</i>	<i>Conditions</i>	<i>Symbol</i>	<i>Min</i>	<i>Typ</i>	<i>Max</i>	<i>Units</i>
Data Rate	10GBASE-LRM module			3.125		GBd
	Relative Tolerance		-100		+100	ppm
Single Ended Input Voltage Swing		V_{ID}	100			mV _{P-P}
Differential Return Loss	100MHz – 2.5GHz	SDD11	10			dB
Total Peak-to-Peak Jitter Tolerance	Sinusoidal Jitter @ 0 ... 20MHz	T_{JRDS}	0.65			UI
Differential Input Impedance		R_{IND}	80	100	120	Ω

Note: XAUI-input-Lanes are ac-inputs.

XAUI Output Characteristics

<i>Parameter</i>	<i>Conditions</i>	<i>Symbol</i>	<i>Min</i>	<i>Typ</i>	<i>Max</i>	<i>Units</i>
XAUI Data Rate	10GBASE-LRM module			3.125		GBd
	XAUI Data Rate Tolerance		-100		+100	ppm
Single Ended Output Voltage Swing	$R_{LOAD} = 100\Omega \pm 5\%$		400		800	mV _{P-P}
Differential Output Impedance		R_{QD}	80	100	120	Ω
Differential Transition Time	20% - 80%		60		130	ps
Total Peak to Peak Jitter					0.27	UI

Note: XAUI-output-Lanes are ac-outputs.

Optical Interface

Recommended Operating Conditions

Parameter	Remark	Symbol	Min	Typ	Max	Units
Operating Range	62.5 um MMF OM1 50um MMF OM2 50um MMF OM3	I_{OP}		0.5 to 220 0.5 to 220 0.5 to 220		m
Input Data Rate	10GBASE-LRM module	DR_o		10.3125		Gbd
	relative tolerance	$\Delta DR/DR_{typ}$	-100		+100	ppm
Receiver Input Signal	Center Wavelength	λ_c	1,260	1,310	1,360	nm

Transmitter Characteristics

if not otherwise mentioned under recommended operating conditions and standard compliant single mode fiber.

Characteristic	Conditions	Symbol	Min	Typ	Max	Units
Data Rate	10GBASE-LRM module	DR		10.3125		Gbps
	relative tolerance to nominal DR	$\Delta DR/DR_{typ}$	-100		100	ppm
Nominal Wavelength		λ_{TRP}	1,260	1,310	1,355	nm
Spectral Width	referred to -20dB points	$\Delta\lambda$			0.2	nm
Side Mode Suppression Ratio		SMSR	30			dB
Optical Output Power		P_{out}	-6.5		0.5	dBm
Extinction Ratio	EOL	ER	3.5	8		dB
Optical Modulation Amplitude		OMA	-4.5		0.5	dBm
Relative Intensity Noise		RIN			-128	dB/Hz

Receiver Characteristics

if not otherwise mentioned under recommended operating conditions and standard compliant single mode fiber.

Parameter	Conditions	Symbol	Min	Typ	Max	Units
Stressed Receiver Sensitivity	OMA	P_{INpp}	-6.5			dBm
Stressed Receiver Sensitivity Symetrical test	OMA	P_{INpp}	-6			dBm
Saturation Input Power	OMA	P_{SAT}	1.5			dBm
SD Deasserted ¹		P_{SDD}	-30			dBm
SD Hysteresis ¹		h_{SD}	0.5			dB
Optical Return Loss		ORL			-12	dB

Note 1: SD-Level is available at D0 from the 10G PMD Receive Signal Detect Register 1.10.

MDIO Interface

DC Characteristics

if not otherwise mentioned under the recommended operating conditions.

Characteristic	Condition	Symbol	Minimum	Maximum	Unit
Input high voltage		V_{IH}	0.84	1.5	V
Input low voltage		V_{IL}	-0.3	0.36	V
MDIO Input current	MMD Driver in tri-state	I_{IMDIO}	-5	5	μA
MDC Input current		I_{IMDC}	-5	5	μA
Output low voltage	$I_{OL} = 100\mu A$	V_{QL}	-0.3		V
	$I_{OL} = 4mA$	V_{QL}		0.2	V
Output high voltage	$I_{OH} = -100\mu A$ $R_{PULL-UP} = 357\Omega \pm 1\%$ $V_{PULL-UP} = 0.95 \dots 1.5V$	V_{QH}	0.95	1.5	V
Output low current	$V_I = 0.2V$	I_{QL}	+4		mA
MDIO Input capacitance	$V_I = 0 \dots 1.5V$	C_{in}		10	pF

AC Characteristics

if not otherwise mentioned under the recommended operating conditions. Furthermore its recommended that clock period time T_{MDC} is not less than 310ns and the sum of input currents of loads on the bus does not exceed 256 μA at high and at low not below -320 μA .

Characteristic	Condition	Symbol	Minimum	Maximum	Unit
Set Up Time		t_{set}		10	ns
Hold Time		t_{hold}		10	ns
Clock to Data Time	$R_{PULL-UP} = 357\Omega \pm 1\%$, $C_{BUS} \leq 470pF$	t_{C2D}	0	300	ns

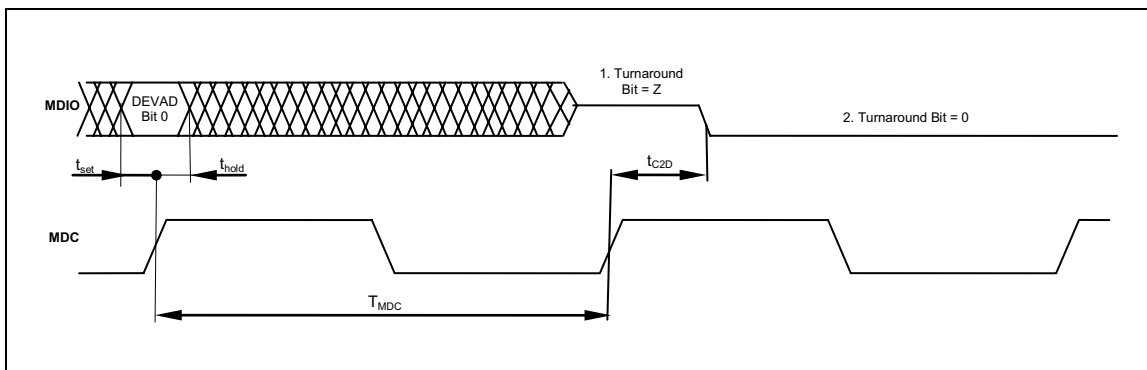

Example Timing Diagram: Turnover Timing at Read Cycle

Electro Static Discharge (ESD)

The maximum electrostatic charge based on a human body model and the conditions as outlined below is:

<i>Parameter</i>	<i>Conditions</i>	<i>Symbol</i>	<i>Min</i>	<i>Typ</i>	<i>Max</i>	<i>Units</i>
Static Discharge Voltage	MIL STD 883 Method 3015.1			500	V	

Thermal Management

The transponder is designed for an operation within a case temperature range between 0 to +70°C at an altitude of < 3km. The built in heatsink provides an optimized thermal performance. The user needs to guarantee per system design not to exceed this temperature range. It has to be considered that in case of usage of multiple modules on a single hostboard that there is a temperature rise among the modules hosted side by side (see figure below). Airflow direction and air speed needs to be chosen accordingly. For further information it is referred to the MSA document.

Card-Edge-Connector-Pinning and Layout

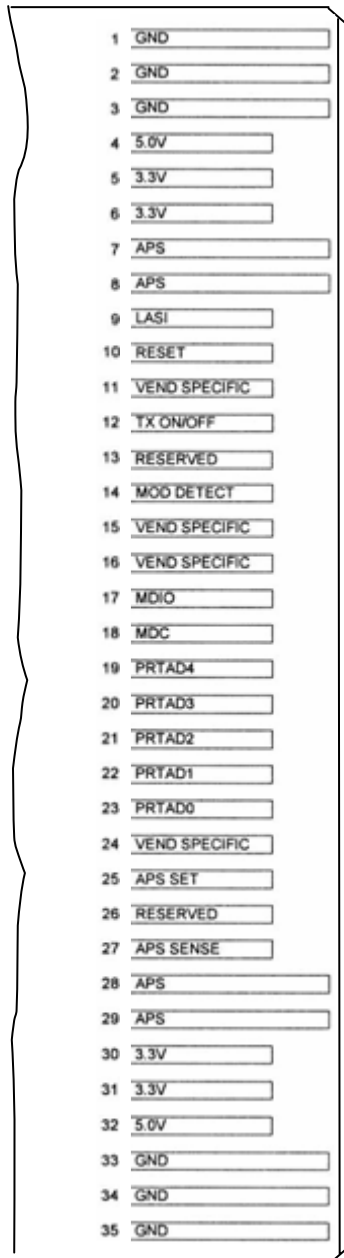

Top view -Top side

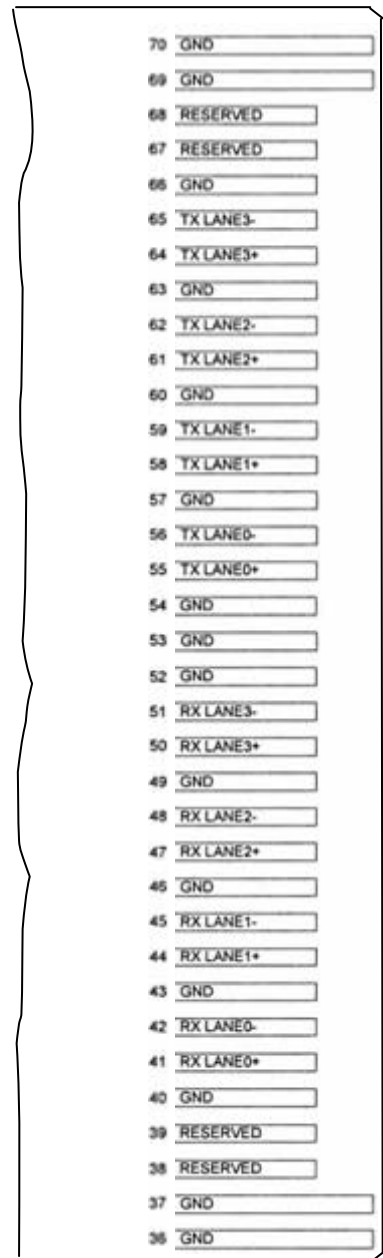

Top view-Bottom row
 (as seen through PCB)

Electrical Pin Definition – Pins 01 to 40 of 70

<i>Symbol</i>	<i>Logic</i>	<i>PIN</i>	<i>Name / Description</i>	<i>Note</i>
3.3V		5, 6, 30, 31	Power Supply of Optical Receiver and Transmitter and Control Circuits	2
5.0V		4, 32	Power Supply of Optical Receiver Frontend	2
APS		7, 8, 28, 29	Adaptive Power Supply, Supply of PHY XS and PCS Layer Devices	2
APS SENSE		27	APS Sense Output for APS Control Circuit	
APS SET		25	Feedback Input for APS, Input of APS Setting Resistor	
GND		1, 2, 3, 33, 34, 35, 36, 37, 40, 43, 46, 49, 52, 53, 54, 57, 60, 63, 66, 69, 70	Common Electrical Ground	1
LASI	1.2V CMOS Open Drain Output	9	Link Alarm Status Interrupt, low active, Open Drain Output Supposed to operate with 10K Ω - 22K Ω pull upon host. Logic High: Normal Operation Logic Low: Link Alarm is indicated	
MDC		18	Management Clock Input	3
MDIO		17	Management Data IO	3
MOD DETECT		14	1k Ω to Ground for APS Circuit Environment	
PRTADO	1.2V CMOS Input	23	Port Address Bit 0 (Low = 0), internally pulled up by 18k Ω	
PRTAD1	1.2V CMOS Input	22	Port Address Bit 1 (Low = 0), internally pulled up by 18k Ω	
PRTAD2	1.2V CMOS Input	21	Port Address Bit 2 (Low = 0), internally pulled up by 18k Ω	
PRTAD3	1.2V CMOS Input	20	Port Address Bit 3 (Low = 0), internally pulled up by 18k Ω	
PRTAD4	1.2V CMOS Input	19	Port Address Bit 4 (Low = 0), internally pulled up by 18k Ω	
RESERVED		13, 38, 39, 67, 68	Reserved by MSA, internally not connected	
RESERVED		26	Reserved for Avalanche Photodiode use, internally not connected	5
RESET	1.2V CMOS Input	10	Low active Reset Input 10K Ω pull-up on Transceiver Logic high = Normal Operation Logic Low = Reset asserted	
TX ON/OFF	1.2V CMOS Input	12	High active Transmitter Enable Input 10K Ω pull-up on Transceiver Logic high = Transmitter active (normal Operation) And Register Bit 1.9.0 set to low as well Logic Low = shut down of Transmitter	
VENDSPECIFIC		11, 15, 16, 24	Vendor Specific Pin., for proper operation leave unconnected	5

Electrical Pin Definition – Pins 41 to 70 of 70

<i>Symbol</i>	<i>Logic</i>	<i>PIN</i>	<i>Name / Description</i>	<i>Note</i>
RX LANE0+		41	Module XAUI Output Lane 0+	4
RX LANE0-		42	Module XAUI Output Lane 0-	4
RXLANE1+		44	Module XAUI Output Lane 1+	4
RXLANE1-		45	Module XAUI Output Lane 1-	4
RX LANE2+		47	Module XAUI Output Lane 2+	4
RX LANE2-		48	Module XAUI Output Lane 2-	4
RX LANE3+		50	Module XAUI Output Lane 3+	4
RX LANE3-		51	Module XAUI Output Lane 3-	4
TX LANE0+		55	Module XAUI Input Lane 0+	4
TX LANE0-		56	Module XAUI Input Lane 0-	4
TXLANE1 +		58	Module XAUI Input Lane 1+	4
TXLANE1-		59	Module XAUI Input Lane 1-	4
TX LANE2+		61	Module XAUI Input Lane 2+	4
TX LANE2-		62	Module XAUI Input Lane 2-	4
TX LANE3+		64	Module XAUI Input Lane 3+	4
TX LANE3-		65	Module XAUI Input Lane 3-	4

- 1) Ground connections are common for TX and RX.
- 2) Each connector contact is rated at 0.5A.
- 3) MDIO and MDC timing must comply with IEEE 802.3ae clause 45.3.
- 4) XAUI output characteristics comply with IEEE 802.3ae clause 47.
- 5) Transceivers will be MSA compliant when no signals are present on the vendor specific pins

Eye Safety

This laser based multimode transceiver is a Class 1 product. It complies with IEC 60825-1/A2: 2001 and FDA performance standards for laser products (21 CFR 1040.10 and 1040.11) except for deviations pursuant to Laser Notice 50, dated July 26, 2001.

CLASS 1 LASER PRODUCT

To meet laser safety requirements the transceiver shall be operated within the Absolute Maximum Ratings.

Note: All adjustments have been made at the factory prior to shipment of the devices. No maintenance or alteration to the device is required. Tampering with or modifying the performance of the device will result in voided product warranty. Failure to adhere to the above restrictions could result in a modification that is considered an act of "manufacturing", and will require, under law, recertification of the modified product with the U.S. Food and Drug Administration (ref. 21 CFR 1040.10 (i)).

Laser Emission Data

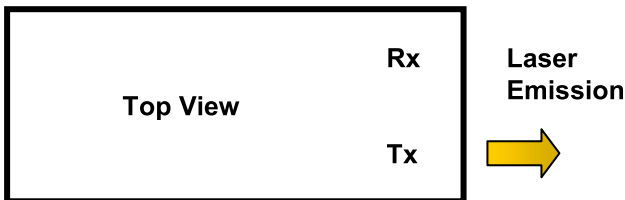

Wavelength	1310 nm
Maximum total output power (as defined by IEC: 7 mm aperture at 14 mm distance)	15.6 mW / 11.9 dBm
Beam divergence (full angle) / NA (half angle)	11° / 0.1 rad

Required Labeling

FDA

Compliant to 21 CFR
1040.10 and 1040.11

IEC

Class 1 Laser Product

Mechanical Drawing

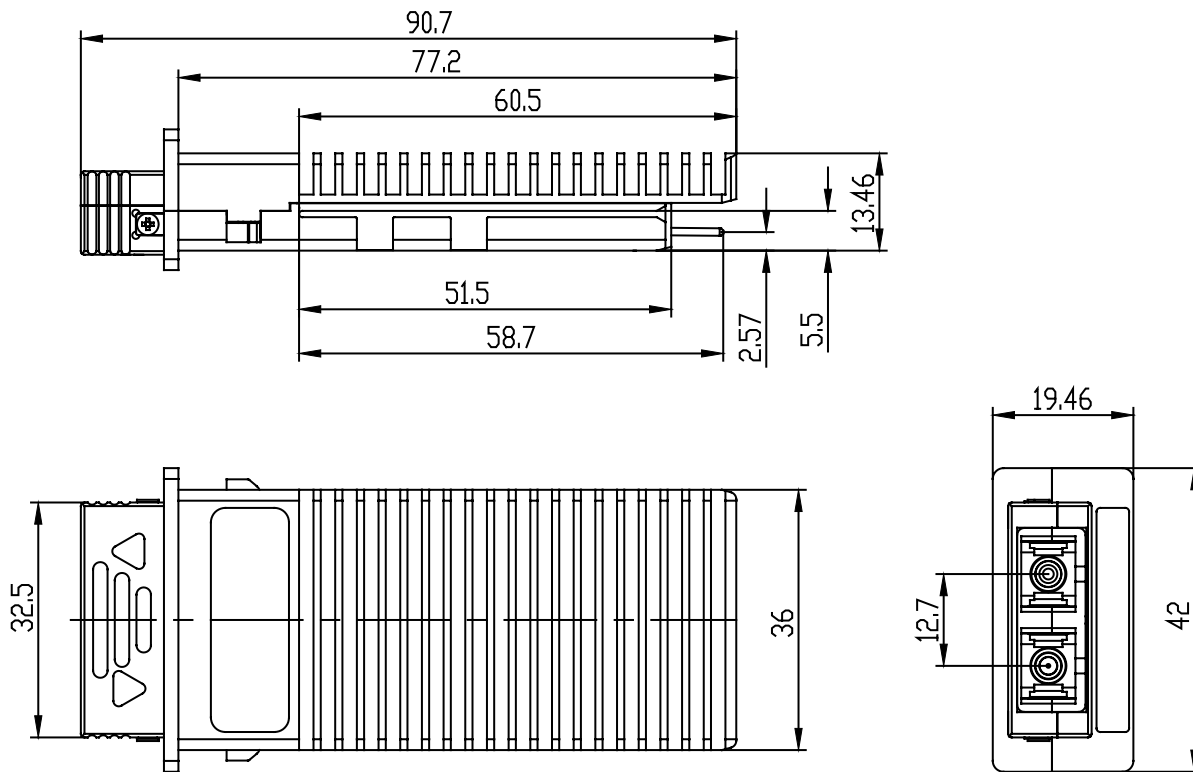

Order Information

Application	Standard	Part Number
10G Ethernet	IEEE 802.3ae 10GBASE-LRM	TRP10GDL0603 TRP10GDL06CA (HP customized)

■ EUROPE

FCI Deutschland GmbH

Wernerwerkdamm 16
13629 Berlin, Germany
Ph: +49 30 750 795 00
Fax: +49 30 386 37 54

■ AMERICAS

MergeOptics

1551 McCarthy Blvd, Suite 116
Milpitas, CA 95035 USA
Phone: 408-493-9970

More information about FCI's complete range of High Speed Input/Output products can be found on www.fciconnect.com/hsio

For more information about e-catalog or FCI sales offices, headquarters, agents and local distributors, visit www.fciconnect.com



ELXTRP10GDL1110EA4